

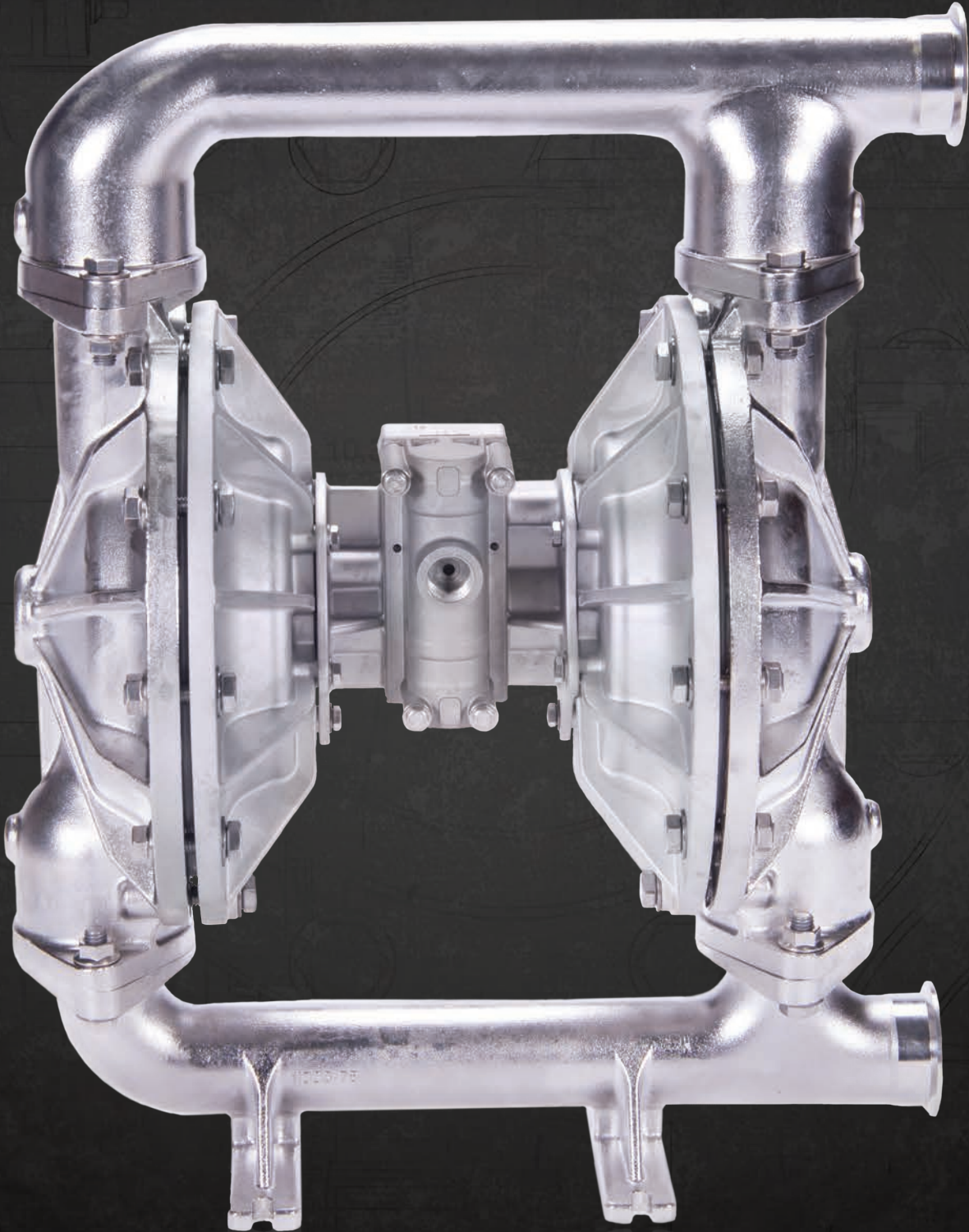

ALL-FLO
PUMP CO.



F-SERIES FDA AIR DIAPHRAGM PUMPS

FDA AIR DIAPHRAGM PUMPS



FDA PUMPS

- FDA Grade Elastomers
- Electropolished and Passivated Stainless Steel Wet End Parts
- Oversized Tri-Clamp Connection Standard
- Limited Tools for Complete Servicing

	F100	F150	F200
DIMENSION			
Air Inlet	1/2" FNPT	3/4" FNPT	3/4" FNPT
Liquid Inlet	1-1/2" Tri-Clamp	2" Tri-Clamp	2-1/2" Tri-Clamp
Liquid Outlet	1-1/2" Tri-Clamp	2" Tri-Clamp	2-1/2" Tri-Clamp
Weight	38 lbs (17kg)	72 lbs (33 kg)	115 lbs (52 kg)

	F100	F150	F200
PERFORMANCE			
Max Capacity	48 gpm (182 lpm)	115 gpm (435 lpm)	190 gpm (719 lpm)
Max Pressure		120 psi (8.2 bar)	
Max Solids	1/4" (6.4 mm)	1/4" (6.4 mm)	1/4" (6.4 mm)
Suction Lift Dry	17 ft-H ₂ O (5.2 m-H ₂ O)	22 ft-H ₂ O (6.7 m-H ₂ O)	24.4 ft-H ₂ O (7.4 m-H ₂ O)
Suction Lift Wet	30 ft-H ₂ O (9.1 m-H ₂ O)	31 ft-H ₂ O (9.4 m-H ₂ O)	31.7 ft-H ₂ O (9.7 m-H ₂ O)

MODEL DESIGNATION MATRIX

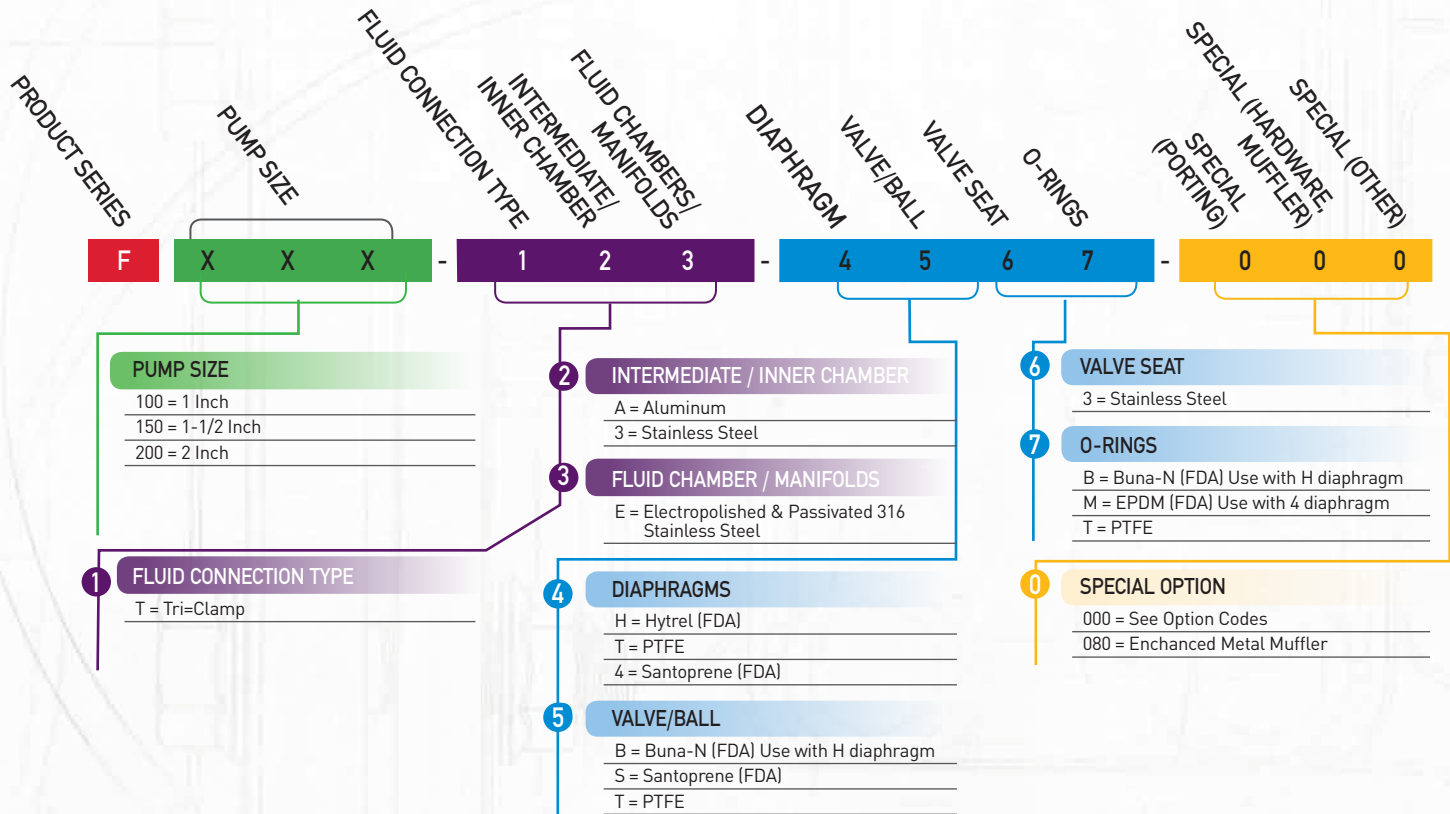

WET END REPAIR KIT

Wet end kit contains 2 diaphragms, (2 back-up diaphragms if required), 4 balls, 4 seats, and 4 seat o-rings.

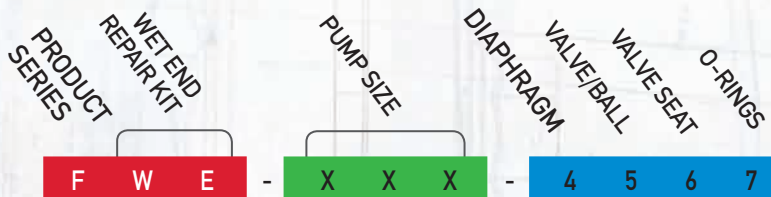

AIR END REPAIR KIT

Air end repair kit contains pilot sleeve assembly and main air valve.

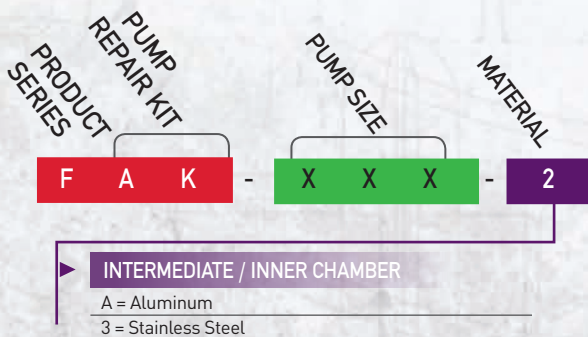

Pulsation Dampener

- Smooths Discharge Flow and Pressure
- Automatic Self-Charging and Self-Venting
- Sanitary AISI 316 Stainless Steel Housing Material
- Sanitary Tri-Clamp Connections
- FDA and Sanitary Grade Elastomers
- 3/8, 1/2, 3/4, 1, 1-1/2, 2, 3 Inch Sizes Available

See Pulsation Dampener Flyer for Additional Information and Product Specifications

F100 - PERFORMANCE CURVES

PERFORMANCE CURVE (1" RUBBER)*

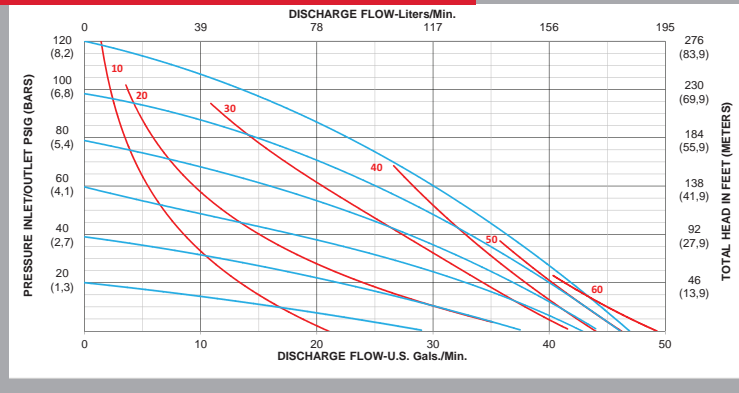

Performance Specifications

Max. Flow:	48 gpm (182 lpm)
Max. Air Pressure:	120 psi (8.3 bar)
Max. Solids:	1/4" (6.4 mm)
Max. Suction Lift Dry:	17 ft-H ₂ O (5.2 m-H ₂ O)
Max. Suction Lift Wet:	30 ft-H ₂ O (9.1 m-H ₂ O)
Weight:	38 lbs (17 kg)
Air Inlet:	1/2" FNPT
Liquid Inlet:	1-1/2" Tri-Clamp
Liquid Outlet:	1-1/2" Tri-Clamp
Height:	16.2" (411 mm)
Width:	13.0" (330 mm)
Depth:	8.4" (213 mm)

PERFORMANCE CURVE (1" TPE)*

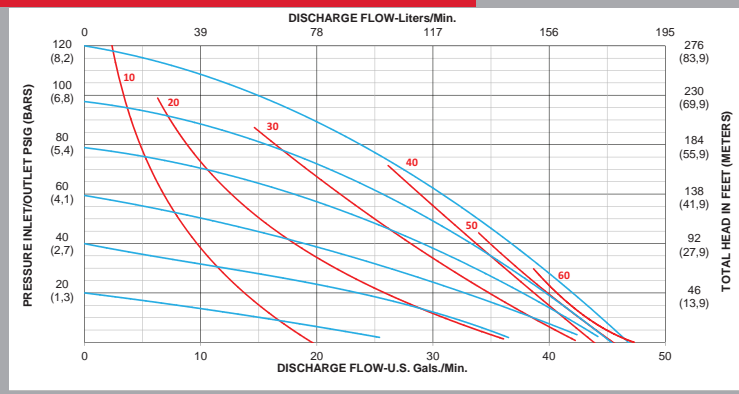

Performance Specifications

Max. Flow:	48 gpm (182 lpm)
Max. Air Pressure:	120 psi (8.3 bar)
Max. Solids:	1/4" (6.4 mm)
Max. Suction Lift Dry:	17 ft-H ₂ O (5.2 m-H ₂ O)
Max. Suction Lift Wet:	30 ft-H ₂ O (9.1 m-H ₂ O)
Weight:	38 lbs (17 kg)
Air Inlet:	1/2" FNPT
Liquid Inlet:	1-1/2" Tri-Clamp
Liquid Outlet:	1-1/2" Tri-Clamp
Height:	16.2" (411 mm)
Width:	13.0" (330 mm)
Depth:	8.4" (213 mm)

PERFORMANCE CURVE (1" PTFE)*

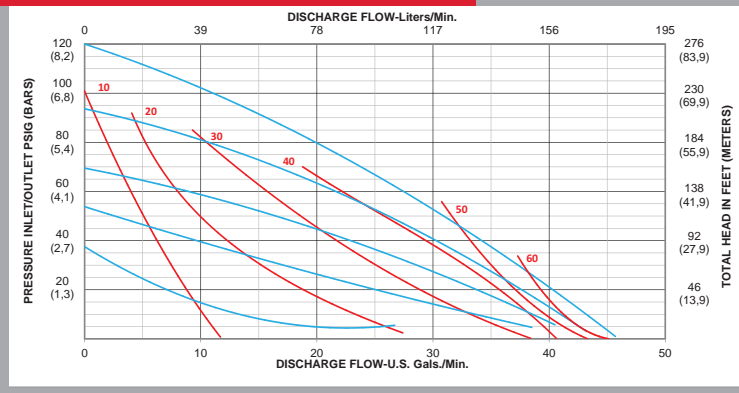

Performance Specifications

Max. Flow:	45 gpm (170 lpm)
Max. Air Pressure:	120 psi (8.3 bar)
Max. Solids:	1/4" (6.4 mm)
Max. Suction Lift Dry:	17 ft-H ₂ O (5.2 m-H ₂ O)
Max. Suction Lift Wet:	30 ft-H ₂ O (9.1 m-H ₂ O)
Weight:	38 lbs (17 kg)
Air Inlet:	1/2" FNPT
Liquid Inlet:	1-1/2" Tri-Clamp
Liquid Outlet:	1-1/2" Tri-Clamp
Height:	16.2" (411 mm)
Width:	13.0" (330 mm)
Depth:	8.4" (213 mm)

*Flow rates indicated on all three charts shown were determined by pumping water at flooded suction, using an aluminum intermediate fitted pump. For optimum life and performance, pumps should be specified so that daily operation parameters will fall in the center of the pump performance curve.

F100 - DIMENSIONS

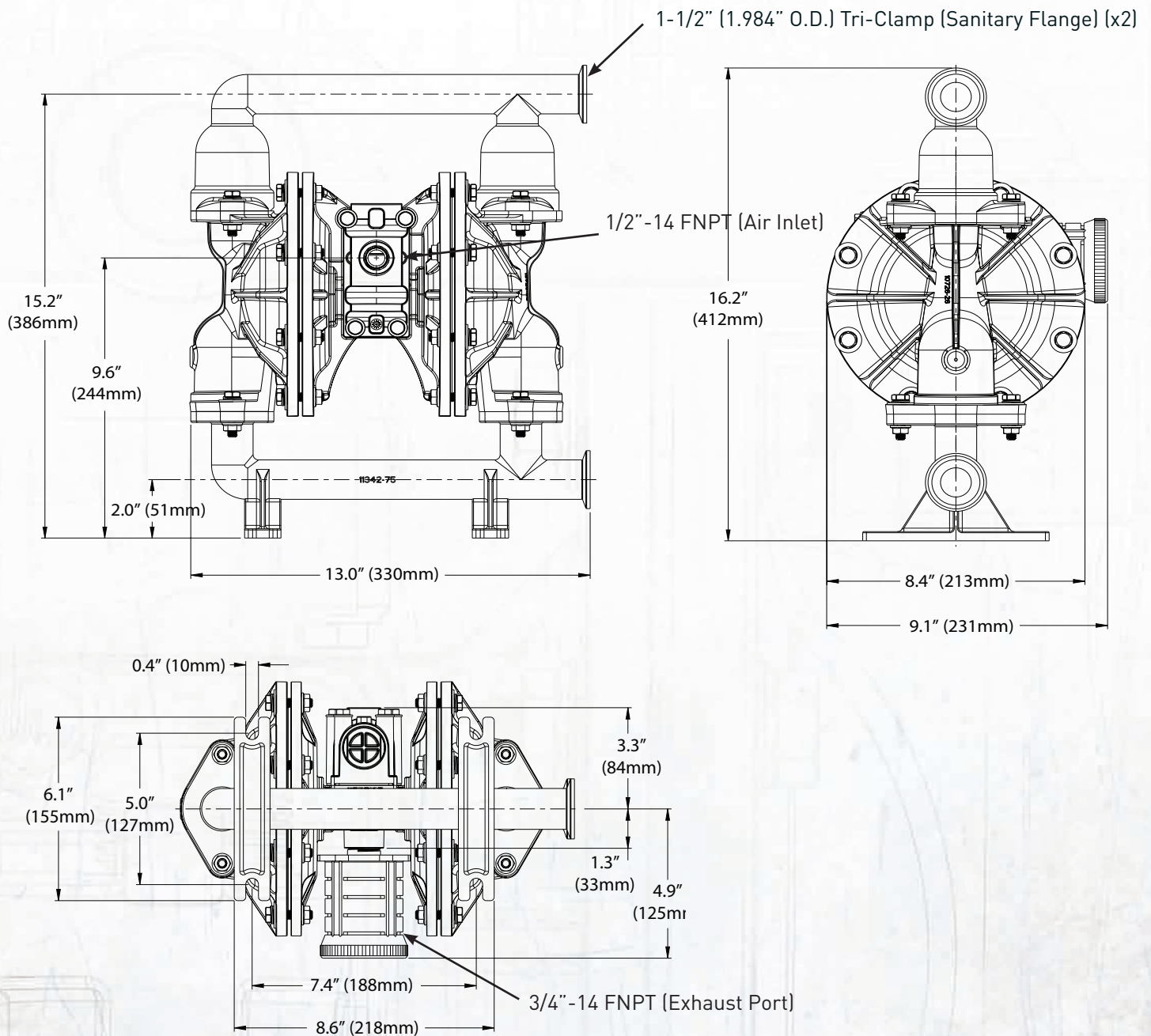

* Note - Suction / Discharge right are default ports. See part number matrix option code for additional porting options.

F150 - PERFORMANCE CURVES

PERFORMANCE CURVE (1-1/2" RUBBER)*

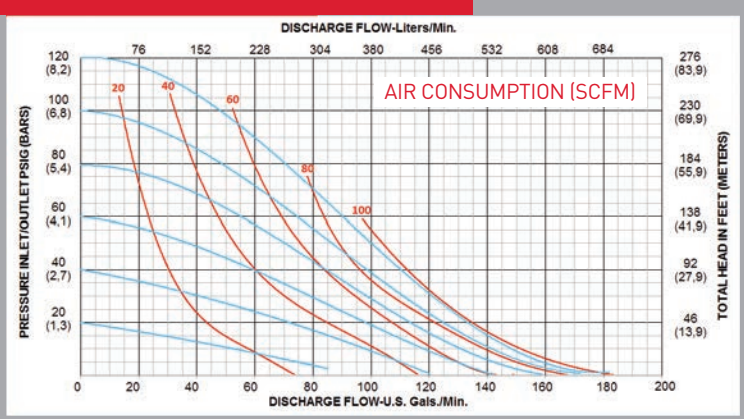

Performance Specifications

Max. Flow:	115 gpm (435 lpm)
Max. Air Pressure:	120 psi (8.3 bar)
Max. Solids:	1/4" (6.4 mm)
Max. Suction Lift Dry:	22 ft-H ₂ O (6.7 m-H ₂ O)
Max. Suction Lift Wet:	31 ft-H ₂ O (9.4 m-H ₂ O)
Weight:	72 lbs (33 kg)
Air Inlet:	3/4" FNPT
Liquid Inlet:	2" Tri-Clamp
Liquid Outlet:	2" Tri-Clamp
Height:	20.6" (523 mm)
Width:	19.1" (485 mm)
Depth:	11.2" (284 mm)

PERFORMANCE CURVE (1-1/2" TPE)*

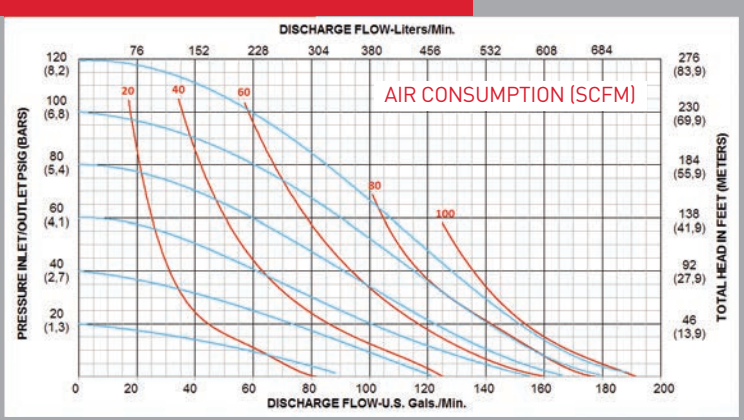

Performance Specifications

Max. Flow:	115 gpm (435 lpm)
Max. Air Pressure:	120 psi (8.3 bar)
Max. Solids:	1/4" (6.4 mm)
Max. Suction Lift Dry:	22 ft-H ₂ O (6.7 m-H ₂ O)
Max. Suction Lift Wet:	31 ft-H ₂ O (9.4 m-H ₂ O)
Weight:	72 lbs (33 kg)
Air Inlet:	3/4" FNPT
Liquid Inlet:	2" Tri-Clamp
Liquid Outlet:	2" Tri-Clamp
Height:	20.6" (523 mm)
Width:	19.1" (485 mm)
Depth:	11.2" (284 mm)

PERFORMANCE CURVE (1-1/2" PTFE)*

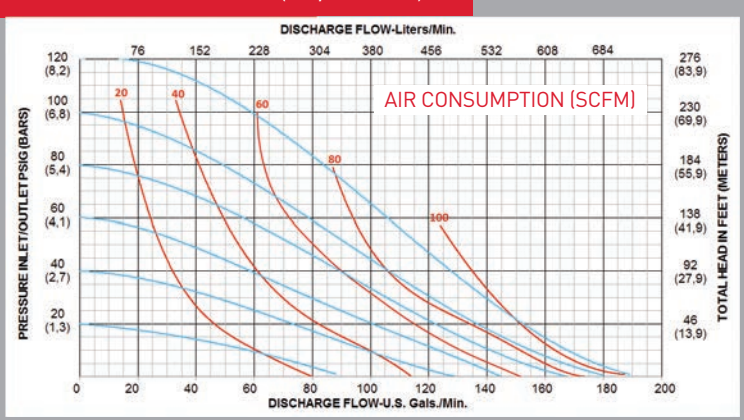

Performance Specifications

Max. Flow:	115 gpm (435 lpm)
Max. Air Pressure:	120 psi (8.3 bar)
Max. Solids:	1/4" (6.4 mm)
Max. Suction Lift Dry:	18 ft-H ₂ O (5.5 m-H ₂ O)
Max. Suction Lift Wet:	31 ft-H ₂ O (9.4 m-H ₂ O)
Weight:	72 lbs (33 kg)
Air Inlet:	3/4" FNPT
Liquid Inlet:	2" Tri-Clamp
Liquid Outlet:	2" Tri-Clamp
Height:	20.6" (523 mm)
Width:	19.1" (485 mm)
Depth:	11.2" (284 mm)

*Flow rates indicated on all three charts shown were determined by pumping water at flooded suction, using an aluminum intermediate fitted pump. For optimum life and performance, pumps should be specified so that daily operation parameters will fall in the center of the pump performance curve.

F150 - DIMENSIONS

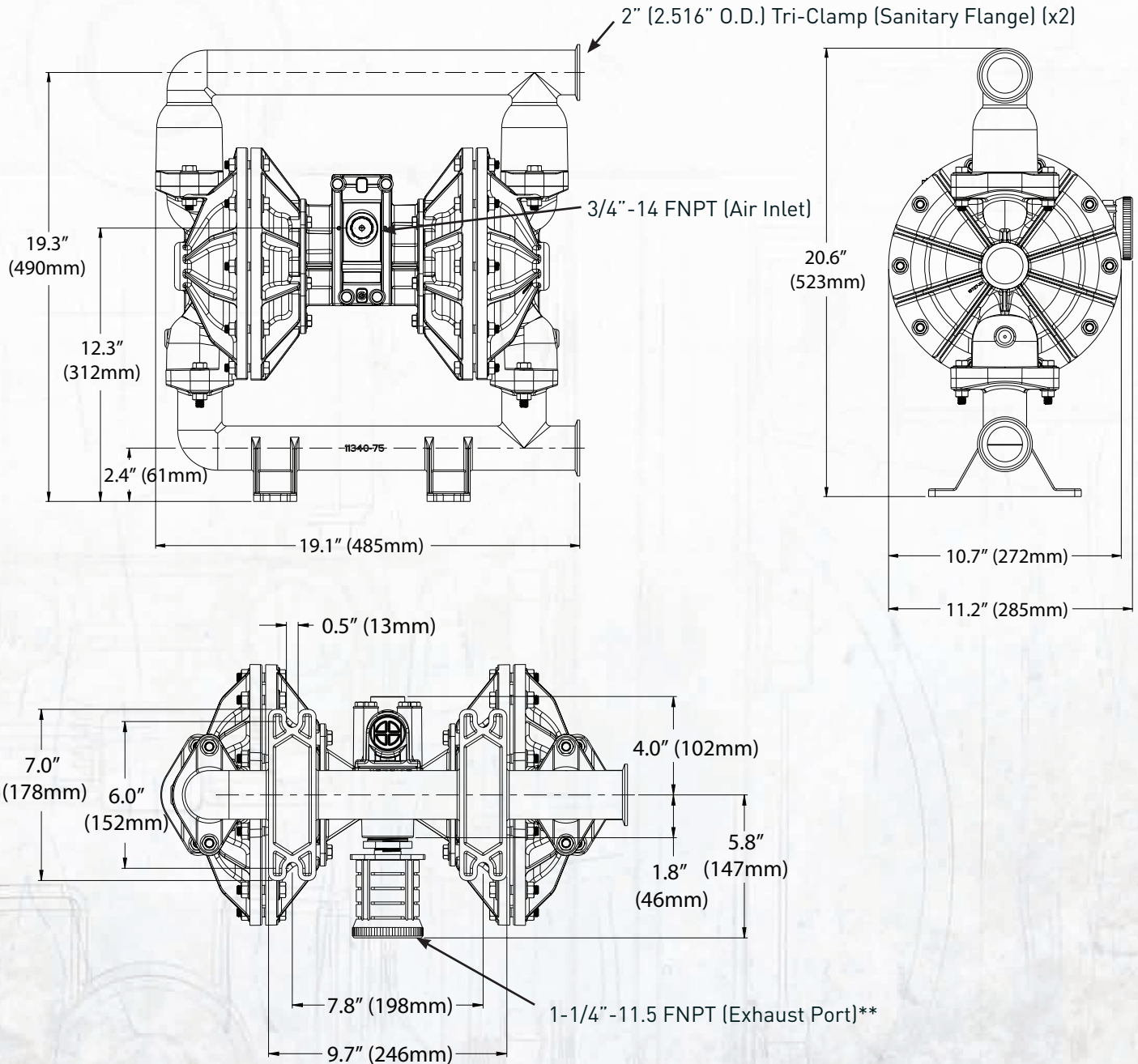

* Note - Suction / Discharge right are default ports. See part number matrix option code for additional porting options.

**Note: A reducer bushing is included with the standard muffler which reduces the port to 3/4"-14 FNPT.

F200 - PERFORMANCE CURVES

PERFORMANCE CURVE (2" RUBBER)*

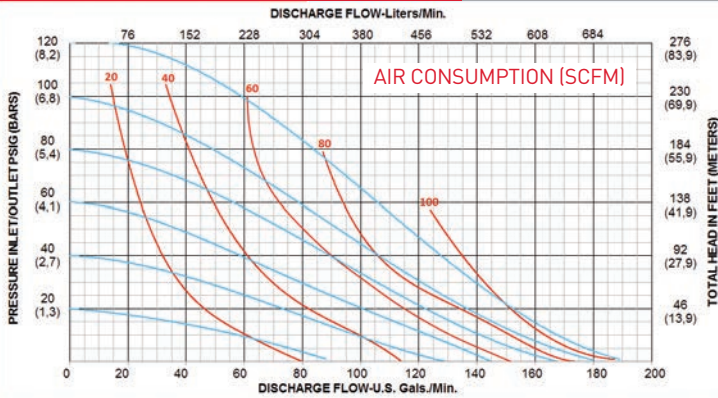

Performance Specifications

Max. Flow:	190 gpm (719 lpm)
Max. Air Pressure:	120 psi (8.3 bar)
Max. Solids:	1/4" (6.4 mm)
Max. Suction Lift Dry:	24.4 ft-H ₂ O (7.4 m-H ₂ O)
Max. Suction Lift Wet:	31.7 ft-H ₂ O (9.7 m-H ₂ O)
Weight:	115 lbs (52 kg)
Air Inlet:	3/4" FNPT
Liquid Inlet:	2-1/2" Tri-Clamp
Liquid Outlet:	2-1/2" Tri-Clamp
Height:	25.9" (658 mm)
Width:	20.5" (521 mm)
Depth:	13.5" (343 mm)

PERFORMANCE CURVE (2" TPE)*

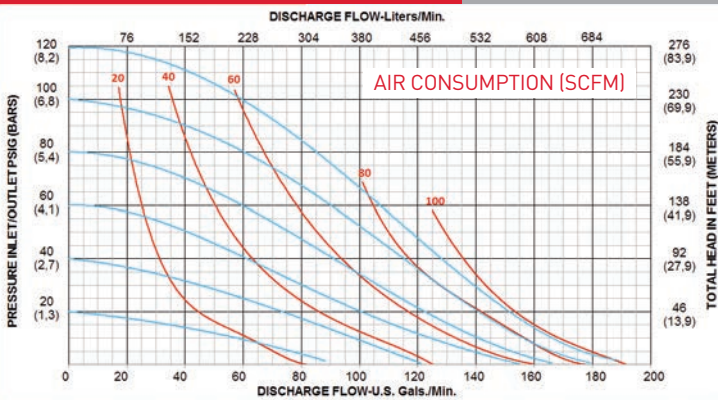

Performance Specifications

Max. Flow:	190 gpm (719 lpm)
Max. Air Pressure:	120 psi (8.3 bar)
Max. Solids:	1/4" (6.4 mm)
Max. Suction Lift Dry:	24.4 ft-H ₂ O (7.4 m-H ₂ O)
Max. Suction Lift Wet:	31.7 ft-H ₂ O (9.7 m-H ₂ O)
Weight:	115 lbs (52 kg)
Air Inlet:	3/4" FNPT
Liquid Inlet:	2-1/2" Tri-Clamp
Liquid Outlet:	2-1/2" Tri-Clamp
Height:	25.9" (658 mm)
Width:	20.5" (521 mm)
Depth:	13.5" (343 mm)

PERFORMANCE CURVE (2" PTFE)*

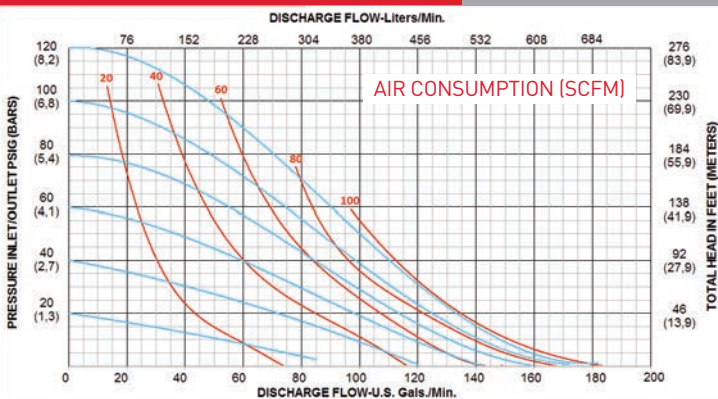

Performance Specifications

Max. Flow:	180 gpm (681 lpm)
Max. Air Pressure:	120 psi (8.3 bar)
Max. Solids:	1/4" (6.4 mm)
Max. Suction Lift Dry:	19.3 ft-H ₂ O (5.9 m-H ₂ O)
Max. Suction Lift Wet:	31.7 ft-H ₂ O (9.7 m-H ₂ O)
Weight:	115 lbs (52 kg)
Air Inlet:	3/4" FNPT
Liquid Inlet:	2-1/2" Tri-Clamp
Liquid Outlet:	2-1/2" Tri-Clamp
Height:	25.9" (658 mm)
Width:	20.5" (521 mm)
Depth:	13.5" (343 mm)

*Flow rates indicated on all three charts shown were determined by pumping water at flooded suction, using an aluminum intermediate fitted pump. For optimum life and performance, pumps should be specified so that daily operation parameters will fall in the center of the pump performance curve.

F200- DIMENSIONS

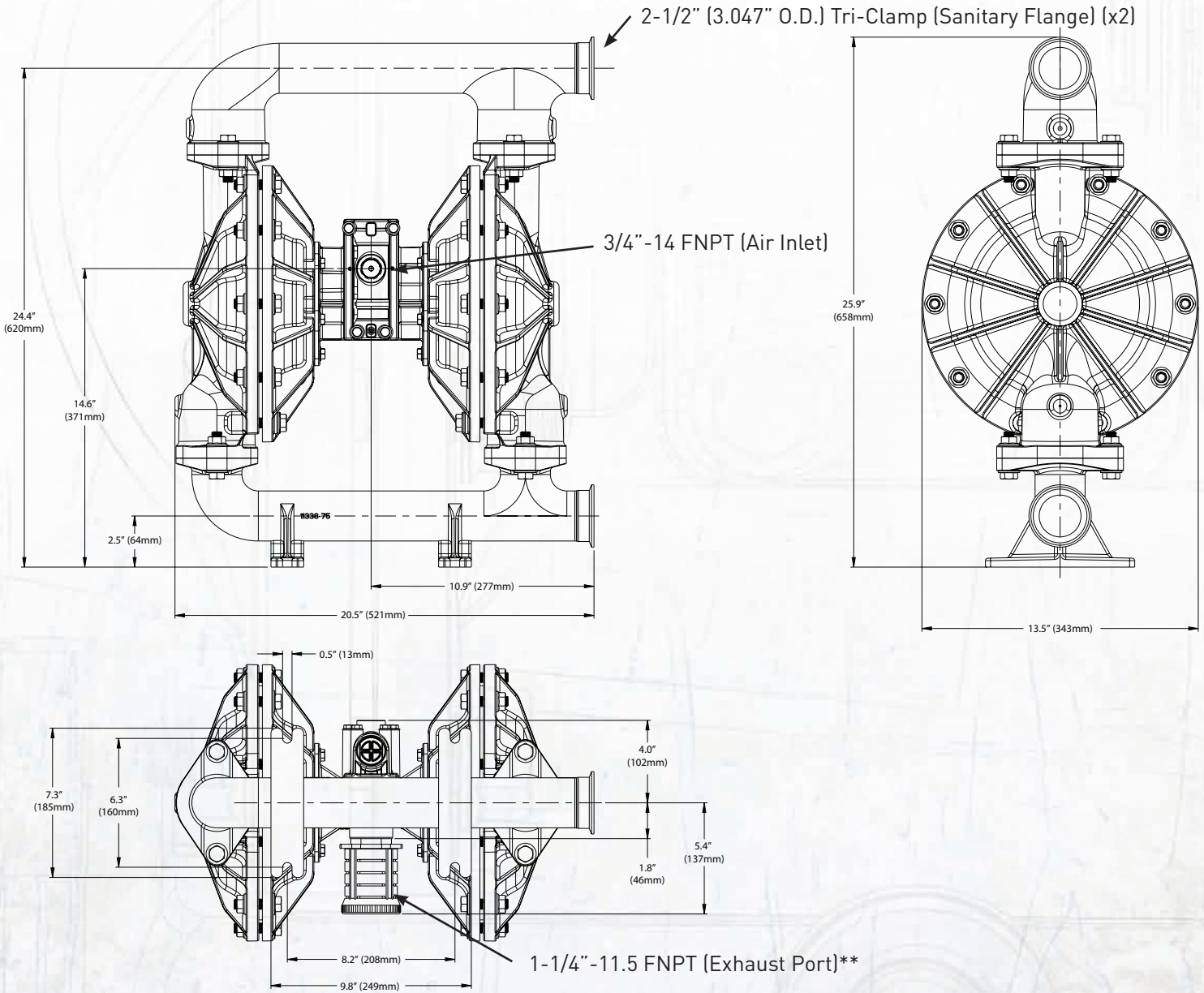

* Note - Suction / Discharge right are default ports. See part number matrix option code for additional porting options.

**Note: A reducer bushing is included with the standard muffler which reduces the port to 3/4"-14 FNPT.



AUTO/PLATING & FINISHING



CERAMIC SLIP / GLAZE



CHEMICAL / PETROCHEMICAL



FOOD & BEVERAGE



MINING



OEMS



OIL & GAS / REFINERY



PAINT & COATING

ALL-FLO is committed to the pursuit of designing and manufacturing the highest quality product available to industry. Since the beginning in 1986, All-Flo engineers have used their extensive knowledge of today's engineered materials, advanced air system logic and manufacturing techniques to develop the superior group of lube-free, air-operated diaphragm pumps found in this catalog. Every pump is performance engineered and quality built to provide trouble-free service under the toughest conditions.

YOUR AUTHORIZED ALL-FLO DISTRIBUTOR



7750 Tyler Blvd.
Mentor, Ohio 44060
phone: 440.354.1700
fax: 440.354.9466
all-flo.com

13965-FXXX_Rev_A3