



OPTIMASS 1400 **Technical Datasheet**

Sensor for mass flow

- First choice for universal applications
- Best price-performance ratio
- A wide range of options available with no restrictions



The documentation is only complete when used in combination with the relevant documentation for the signal converter.

1	Product features	3
<hr/>		
1.1	Overview.....	3
1.2	Features and options.....	5
1.3	Meter / converter combinations.....	6
1.4	Measuring principle (twin tube)	6
2	Technical data	8
<hr/>		
2.1	Technical data.....	8
2.2	ATEX (acc. 94/9/EC) temperature limits	11
2.3	Maximum pipework forces (end loadings).....	12
2.4	Measuring accuracy	13
2.5	Guidelines for maximum operating pressure.....	14
2.6	Dimensions and weights	16
2.6.1	Flanged versions.....	16
2.6.2	Hygienic versions	20
2.6.3	Heating jacket version	24
2.6.4	Purge port option	25
3	Installation	26
<hr/>		
3.1	Intended use	26
3.2	Mounting restrictions	26
3.2.1	General installation principles	26
3.2.2	Sunshades.....	28
4	Notes	29
<hr/>		

1.1 Overview

The OPTIMASS 1400 is the cost effective solution for accurate measurement for a variety of applications. The OPTIMASS 1400 reliably measures massflow, density, volume, temperature, volume concentration or solid content.



- ① Modular electronics with a range of output options (see separate documentation for details).
- ② The power of the MFC 400 gives comprehensive diagnostics together with Entrained Gas Management (EGM).
- ③ Available with a range of flange and hygienic connections.



- ① Remote terminal box

Highlights

- Innovative twin measuring tubes
- Easily drained and easy to clean
- Resistant to installation and process effects
- Long working life.
- Optimised flow divider for minimum pressure loss.
- High levels of accuracy means an excellent price / performance ratio.
- Modular electronics with data redundancy - "plug & play" replacement of electronics

Industries

- Water & wastewater
- Chemical
- Food & beverage
- Paper & pulp
- Petrochemical industry
- Pharmaceutical industry

Applications

- Suitable for all standard applications up to 130°C
- Hygienic connections make it ideal for food / beverage applications.

1.2 Features and options

Features

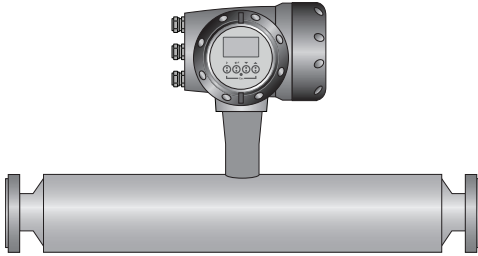

- Available as compact or remote.
- Low pressure loss, guarantees a low pressure drop across the meter.
- Self Draining.
- Easy to clean.

Connection options

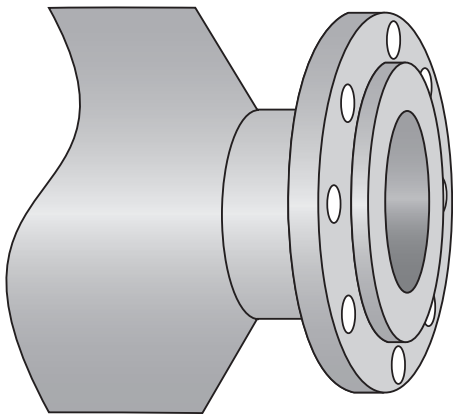

- A range of flanges up to ASME 600 / PN100.
- Supports a wide range of industry standard hygienic connections.
- Adaptable to suit customer's hygienic connections.

Heating jacket & purge port

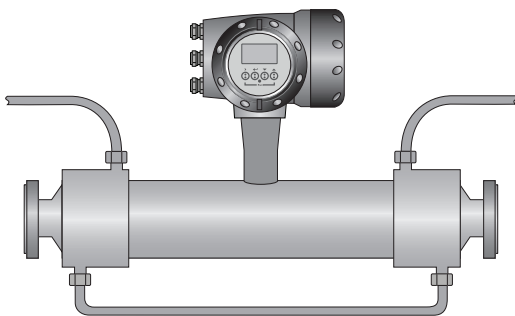

- Heating jacket option for use with temperature dependant products.
- Prevents solidification of process product.
- Purge port option for protection in the event of measuring tube failure.
- Allows hazardous chemicals to be drained away safely.
- Can also be used for the early detection of measuring tube failure where highly toxic chemicals are being measured.

1.3 Meter / converter combinations

Converter	MFC 400	
Configuration	Compact	Remote field
OPTIMASS 2400	1400C	1400F

1.4 Measuring principle (twin tube)

Static meter not energised and with no flow

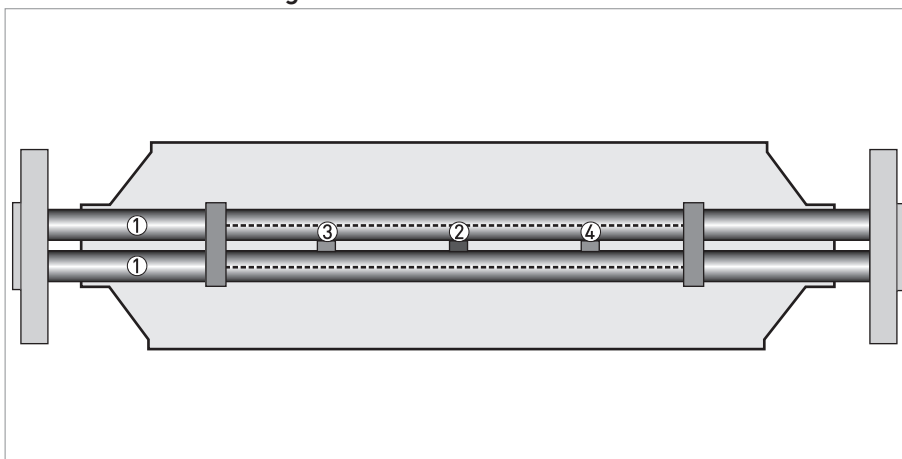

- ① Measuring tubes
- ② Drive coil
- ③ Sensor 1
- ④ Sensor 2

A Coriolis twin tube mass flowmeter consists of two measuring tubes ① a drive coil ② and two sensors (③ and ④) that are positioned either side of the drive coil.

Energised meter

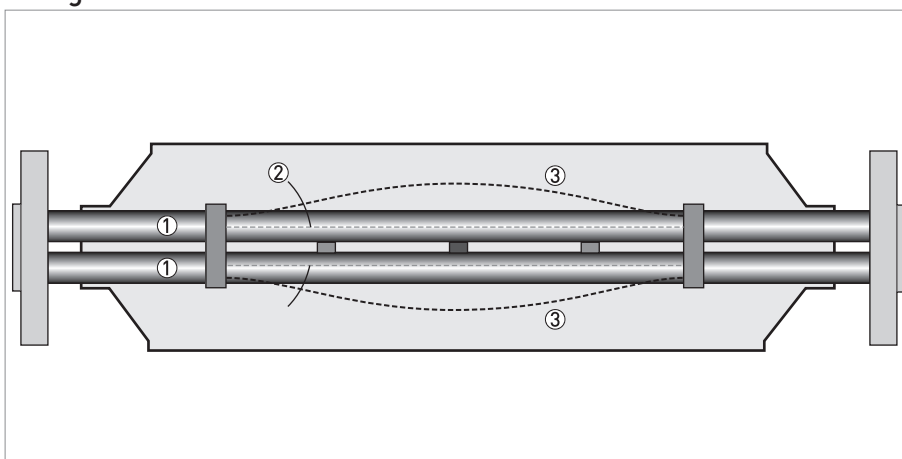

- ① Measuring tubes
- ② Direction of oscillation
- ③ Sine wave

When the meter is energised, the drive coil vibrates the measuring tubes causing them to oscillate and produce a sine wave ③. The sine wave is monitored by the two sensors.

Energised meter with process flow

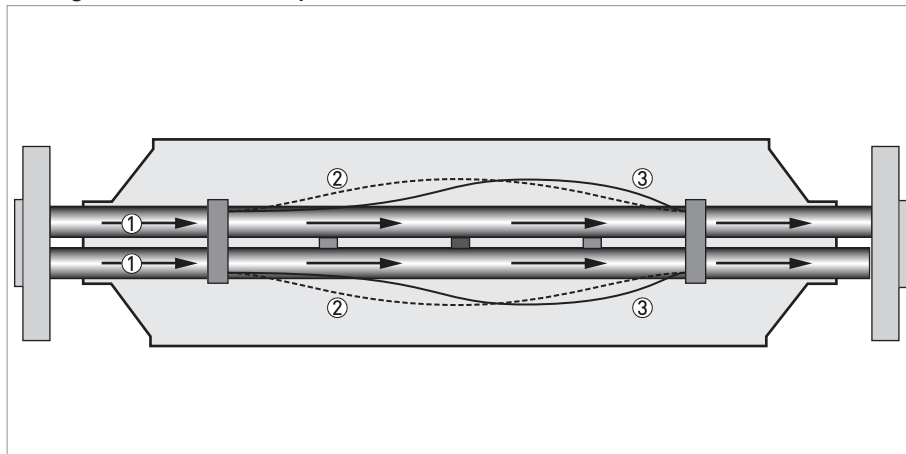

- ① Process flow
- ② Sine wave
- ③ Phase shift

When a fluid or gas passes through the tubes, the coriolis effect causes a phase shift in the sine wave that is detected by the two sensors. This phase shift is directly proportional to the mass flow.

Density measurement is made by evaluation of the frequency of vibration and temperature measurement is made using a Pt500 sensor.

2.1 Technical data

- *The following data is provided for general applications. If you require data that is more relevant to your specific application, please contact us or your local sales office.*
- *Additional information (certificates, special tools, software,...) and complete product documentation can be downloaded free of charge from the website (Download Center).*

Measuring system

Measuring principle	Coriolis mass flow
Application range	Mass flow and density measurement of fluids, gases and solids
Measured values	Mass, density, temperature
Calculated values	Volume, referred density, concentration, velocity

Design

Basic	System consists of a measuring sensor and a converter to process the output signal
Features	Fully welded maintenance free sensor with twin straight measuring tubes
Variants	
Compact version	Integral converter
Remote version	Available with field version of the converter
Modbus version	Sensor with integral electronics providing Modbus output for connection to a PLC

Measuring accuracy

Mass	
Liquid	$\pm 0.15\%$ of actual measured flow rate + zero stability
Gas	$\pm 0.35\%$ of actual measured flow rate + zero stability
Repeatability	Better than 0.05% plus zero stability (includes the combined effects of repeatability, linearity and hysteresis)
Zero stability	
Stainless Steel	$\pm 0.01\%$ of maximum flow rate with respective sensor size
Reference conditions	
Product	Water
Temperature	20°C / 68°F
Operating pressure	1 barg / 14.5 psig
Effect on sensor zero point caused by a shift in process temperature	
Stainless Steel	0.001% per 1°C / 0.00055% per 1°F
Effect on sensor zero point caused by a shift in process pressure	
Stainless Steel	0.00012% of the max flow rate per 1 bar _{rel.} / 0.0000083% of the max flow rate per 1 psig
Density	
Measuring range	400...2500 kg/m ³ / 25...155 lbs/ft ³
Accuracy	± 2 kg/m ³ / ± 0.13 lbs/ft ³ (S15: ± 5 kg/m ³ / ± 0.33 lbs/ft ³)
On site calibration	± 0.5 kg/m ³ / ± 0.033 lbs/ft ³

Temperature	
Accuracy	±1°C / 1.8°F

Operating conditions

Maximum flow rates	
S15	6500 kg/h / 240 lbs/min
S25	27000 kg/h / 990 lbs/min
S40	80000 kg/h / 2935 lbs/min
S50	170000 kg/h / 6235 lbs/min
Ambient temperature	
Compact version with Aluminium converter	-40...+60°C / -40...+140°F
	Extended temperature range: +65°C / +149°F for some I/O options. For more information contact manufacturer.
Compact version with Stainless Steel converter	-40...+55°C / -40...+130°F
Remote versions	-40...+65°C / -40...+149°F
Process temperature	
Flanged connection	-40...+130°C / -40...+266°F
Hygienic connection	-40...+130°C / -40...+266°F
Nominal pressure at 20°C / 68°F	
Measuring tube	
Stainless Steel	-1...100 barg / -14.5...1450 psig
Outer cylinder	
Non PED / CRN approved	Typical burst pressure > 100 barg / 1450 psig at 20°C
PED / CRN approved secondary containment	-1...63 barg / -14.5...910 psig
PED approved secondary containment	-1...100 barg / -14.5...1450 psig
Fluid properties	
Permissible physical condition	Liquids, gases, slurries
Permissible gas content (volume)	Contact manufacturer for information
Permissible solid content (volume)	Contact manufacturer for information
Protection category (acc. to EN 60529)	IP 67, NEMA 4X

Installation conditions

Inlet runs	None required
Outlet runs	None required

Materials

Measuring tube	Stainless Steel UNS S31803 (1.4462)
Spigot	Stainless Steel 316 / 316L (CF3M / 1.4409) dual certified
Flanges	Stainless Steel 316 / 316L (1.4401 / 1.4404) dual certified
Outer cylinder	Stainless Steel 304 / 304L (1.4301 / 1.4307) dual certified
	Optional Stainless Steel 316 / 316L (1.4401 / 1.4404) dual certified
Heating jacket version	
Heating jacket	Stainless Steel 316L (1.4404)
	The outer cylinder is in contact with the heating medium

All versions	
Sensor electronics housing	Stainless Steel 316L (1.4409)
Junction box (remote version)	Die cast Aluminium (polyurethane coating)
	Optional Stainless Steel 316 (1.4401)

Process connections

Flange	
DIN	DN15...80 / PN40...100
ASME	½...3" / ASME 150...600
JIS	15...80A / 10...20K
Hygienic	
Tri-clover	1...3"
Tri-clamp DIN 32676	DN25...80
Tri-clamp ISO 2852	1...3"
DIN 11864-2 Form A	DN25...80
Male thread DIN 11851	DN25...80
Male thread SMS	1...3"
Male thread IDF / ISS	1...3"
Male thread RJT	1...3"

Electrical connections

Electrical connections	For full details, including: power supply, power consumption etc., see technical data for the relevant converter
I/O	For full details of I/O options, including data streams and protocols, see technical data for the relevant converter

Approvals and certifications

Mechanical	
Electromagnetic compatibility (EMC) acc. to CE	Namur NE 21/5.95
	2004/108/EC (EMC)
	2006/95/EC (Low Voltage Directive)
European Pressure Equipment Directive	PED 97-23 EC (acc. to AD 2000 Regelwerk)
Factory Mutual / CSA	Class I, Div 1 groups A, B, C, D
	Class II, Div 1 groups E, F, G
	Class III, Div 1 hazardous areas
	Class I, Div 2 groups A, B, C, D
	Class II, Div 2 groups F, G
	Class III, Div 2 hazardous areas
ANSI / CSA (Dual Seal)	12.27.901-2003
Hygienic	3A 28-03

ATEX (acc. 94/9/EC)	
OPTIMASS 1400C non Ex i Signal outputs without heating jacket / insulation	
Ex d connection compartment	II 1/2 G Ex d ia IIC T6....T1 Ga/Gb
	II 2 D Ex tb IIIC T165°C Db
Ex e connection compartment	II 1/2 G Ex de ia IIC T6....T1 Ga/Gb
	II 2 D Ex tb IIIC T165°C Db
OPTIMASS 1400C non Ex i signal outputs with heating jacket / insulation	
Ex d connection compartment	II 1/2 G Ex d ia IIC T6....T1 Ga/Gb
	II 2 D Ex tb IIIC T165°C Db
Ex e connection compartment	II 1/2 G Ex de ia IIC T6....T1 Ga/Gb
	II 2 D Ex tb IIIC T165°C Db
OPTIMASS 1400C Ex i signal outputs without heating jacket / insulation	
Ex d connection compartment	I 1/2(1) G Ex d ia [ia Ga] IIC T6....T1 Ga/Gb
	II 2(1) D Ex tb [ia Da] IIIC T165°C Db
Ex e connection compartment	I 1/2(1) G Ex de ia [ia Ga] IIC T6....T1 G
	II 2(1) D Ex tb [ia Da] IIIC T165°C Db
OPTIMASS 1400C Ex i signal outputs with heating jacket / insulation	
Ex d connection compartment	I 1/2(1) G Ex d ia [ia Ga] IIC T6....T1 Ga/Gb
	II 2(1) D Ex tb [ia Da] IIIC T165°C Db
Ex e connection compartment	I 1/2(1) G Ex de ia [ia Ga] IIC T6....T1 G
	II 2(1) D Ex tb [ia Da] IIIC T165°C Db

2.2 ATEX (acc. 94/9/EC) temperature limits

	Ambient temp. Tamb °C	Max. medium temp. Tm °C	Temp. class	Max. surface temp. °C	
OPTIMASS 1400C - with or without heating jacket / insulation	40	40	T6	T75	
		55	T5	T90	
		90	T4	T125	
		130	T3 - T1	T165	
	50	55	T5	T90	
		90	T4	T125	
		130	T3 - T1	T165	
	65	75	T4	T110	
		130	T3 - T1	T165	
	OPTIMASS 1400C - aluminium converter housing - with or without heating jacket / insulation	40	40	T6	T75
			55	T5	T90
			90	T4	T125
130			T3 - T1	T165	
50		55	T5	T90	
		90	T4	T125	
		130	T3 - T1	T165	
65		65	T4 - T1	T100	

	Ambient temp. Tamb °C	Max. medium temp. Tm °C	Temp. class	Max. surface temp. °C
OPTIMASS 1400C - SS converter housing - with or without heating jacket / insulation	40	40	T6	T75
		55	T5	T90
		90	T4	T125
		130	T3 - T1	T165
	50	55	T5	T90
		90	T4 - T1	T125
60	60	T5 - T1	T95	

2.3 Maximum pipework forces (end loadings)

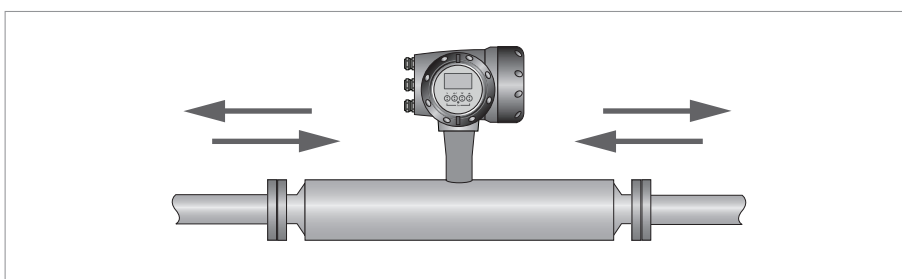

Mass flowmeters have a maximum level of force (negative or positive) that can be applied to the ends of the meter. Refer to the table below for permitted forces.

Maximum end loadings

		S15	S25	S40	S50
Flanges					
20°C	40 barg	25kN	38kN	48kN	99kN
	100 barg	17kN	19kN	15kN	20kN
130°C	32 barg	18kN	28kN	35kN	72kN
	80 barg	12kN	12kN	7kN	8kN
Hygienic (all connections)					
130°C	10 barg	5kN	9kN	12kN	12kN

- These (axial) loads have been calculated, based on 316L schedule 40 process pipework, where un-radiographed butt welds have been used in pipe joints.
- The loads shown are the maximum permitted static load. If loads are cycling (between tension and compression) these loads should be reduced. For advice, consult the manufacturer.

2.4 Measuring accuracy

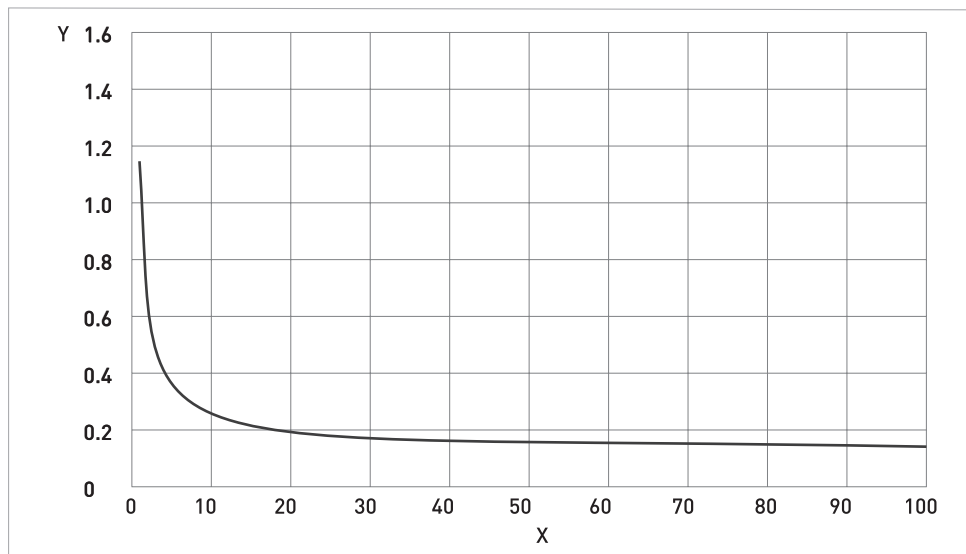

X flow rate [%]

Y measuring error [%]

Measuring error

The measuring error is obtained from the combined effects of accuracy and zero stability.

Reference conditions

Product	Water
Temperature	+20°C / +68°F
Operating pressure	1 barg / 14.5 psig

2.5 Guidelines for maximum operating pressure

Notes:

- Ensure that the meter is used within its operating limits
- All hygienic process connections have a maximum operating rating of 10 barg at 130°C / 145 psig at 266°F

Pressure / temperature de-rating, all meter sizes, in metric (flanged connections as per EN 1092-1)

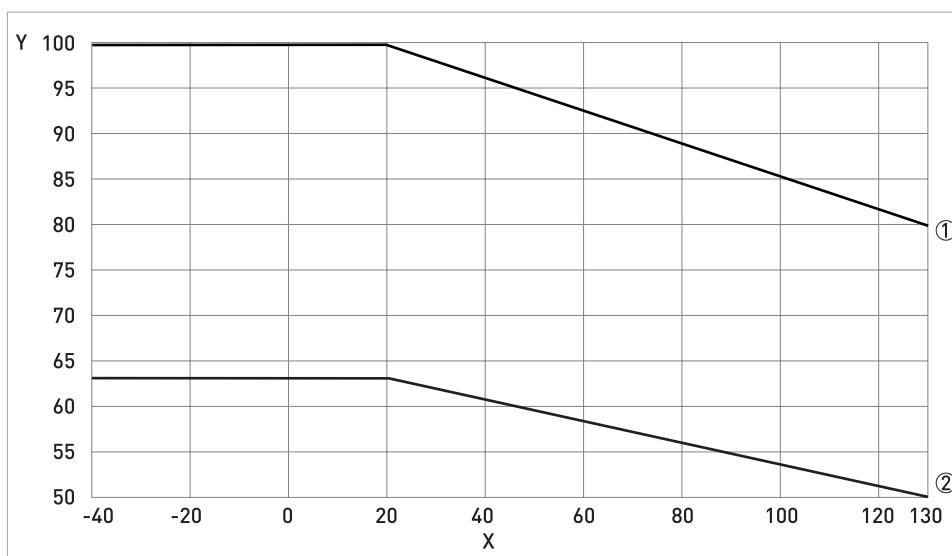

X temperature [°C]

Y pressure [barg]

① Measuring tubes and 100barg 316L secondary containment (PED)

② 63 barg 304L / 316 secondary containment (PED)

Pressure / temperature de-rating, all meter sizes, in imperial (flanged connections as per ASME B16.5)

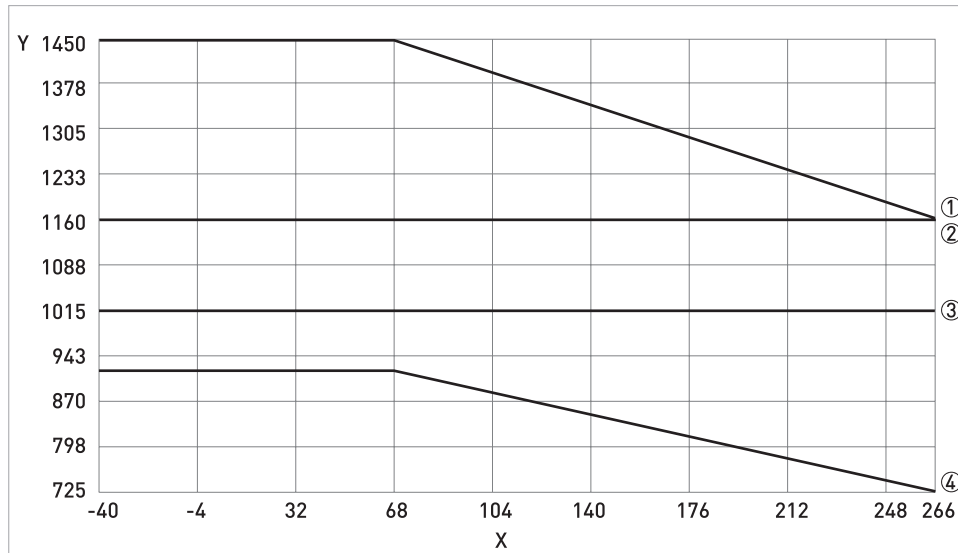

X temperature [°F]

Y pressure [psig]

- ① Measuring tubes S15 / S25 (CRN)
- ② Measuring tubes S40 (CRN)
- ③ Measuring tubes S50 (CRN)
- ④ Secondary containment 304L / 316L (CRN)

Flanges

- DIN flange ratings are based on EN 1092-1 2001 table 18 (1% proof stress) material group 14EO
- ASME flange ratings are based on ASME B16.5 2003 table 2 material group 2.2
- JIS flange ratings are based on JIS 2220: 2001 table 1 division 1 material group 022a

Notes

- The maximum operating pressure will be either the flange rating or the measuring tube rating, **WHICHEVER IS THE LOWER!**
- The manufacturer recommends that the seals are replaced at regular intervals. This will maintain the hygienic integrity of the connection.

2.6 Dimensions and weights

2.6.1 Flanged versions

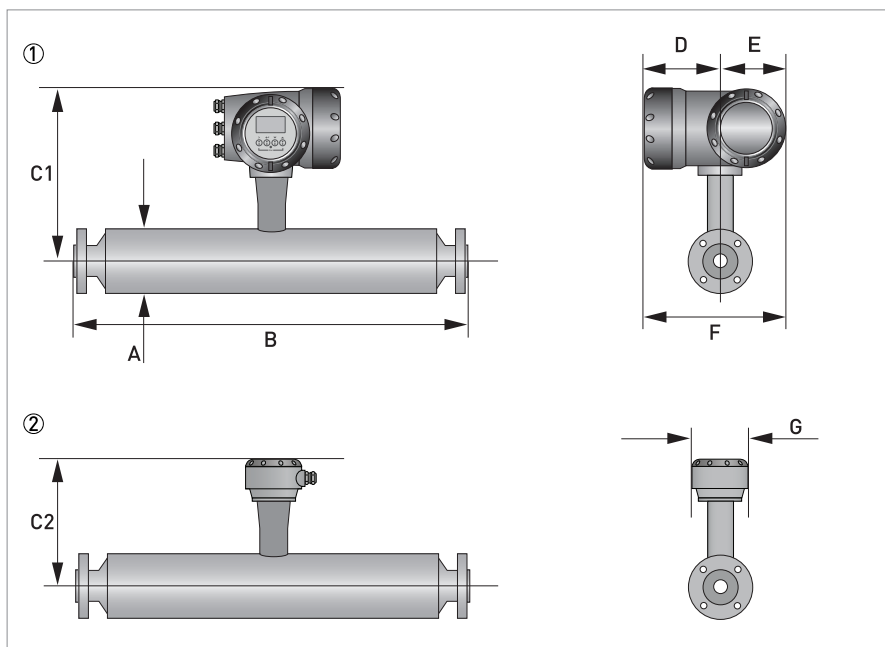

- ① Compact version
- ② Remote version

Meter weights (all flanges)

	Weight [kg]			
	S15	S25	S40	S50
Aluminium (compact)	13.5	16.5	29.5	57.5
Stainless Steel (compact)	18.8	21.8	34.8	62.8
Aluminium (remote)	11.5	14.5	25.5	51.5
Stainless Steel (remote)	12.4	15.4	26.4	52.4

	Weight [lbs]			
	S15	S25	S40	S50
Aluminium (compact)	30	36.3	65	127
Stainless Steel (compact)	41	48	77	138
Aluminium (remote)	25	32	56	113
Stainless Steel (remote)	27	33.8	58	115

Measuring tube in Stainless Steel

	Dimensions [mm]			
	S15	S25	S40	S50
A	101.6	114.3	168.3	219.1
C1 (compact)	311	317	344	370
C2 (remote)	231	237	264	290
D	160			
E	60			
F	123.5			
G	137			
H	98.5			

	Dimensions [inches]			
	S15	S25	S40	S50
A	4	4.5	6.6	8.6
C1 (compact)	12.2	12.5	13.5	14.6
C2 (remote)	9	9.3	10.4	11.4
D	6.3			
E	2.4			
F	4.9			
G	5.4			
H	3.9			

Flange connections

	Dimension B [mm]			
	S15	S25	S40	S50
PN40				
DN15	498	-	-	-
DN25	503	531	-	-
DN40	513	541	706	-
DN50	-	547	712	862
DN80	-	-	732	882
DN100	-	-	-	896
PN63				
DN50	-	-	740	890
DN80	-	-	-	910
PN100				
DN15	513	-	-	-
DN25	538	567	-	-
DN40	-	575	740	-
DN50	-	-	752	902
DN80	-	-	-	922

ASME 150				
½"	518	-	-	-
¾"	528	-	-	-
1"	534	563	-	-
1½"	-	575	740	-
2"	-	579	744	894
3"	-	-	756	906
4"	-	-	-	920
ASME 300				
½"	528	-	-	-
¾"	538	-	-	-
1"	546	575	-	-
1½"	-	589	754	-
2"	-	-	756	906
3"	-	-	-	926
ASME 600				
½"	541	-	-	-
¾"	550	-	-	-
1"	558	589	-	-
1½"	-	603	770	-
2"	-	-	774	926
3"	-	-	-	944
JIS 10K				
50A	-	-	712	862
80A	-	-	-	882
JIS 20K				
15A	498	-	-	-
25A	503	531	-	-
40A	-	541	706	-
50A	-	-	712	862
80A	-	-	-	882

	Dimension B [inches]			
	S15	S25	S40	S50
PN40				
DN15	19.6	-	-	-
DN25	19.8	21	-	-
DN40	20.2	21.3	27.8	-
DN50	-	21.5	28	33.9
DN80	-	-	28.8	34.7
DN100	-	-	-	35.3

PN63				
DN50	-	-	29	35
DN80	-	-	-	35.8
PN100				
DN15	20.2	-	-	-
DN25	21.2	22.3	-	-
DN40	-	22.6	29	-
DN50	-	-	29.6	35.5
DN80	-	-	-	36.3
ASME 150				
½"	20.4	-	-	-
¾"	20.8	-	-	-
1"	21	22.2	-	-
1½"	-	22.5	29.1	-
2"	-	22.8	29.3	35.2
3"	-	-	29.8	35.7
4"	-	-	-	36.2
ASME 300				
½"	20.8	-	-	-
¾"	21.2	-	-	-
1"	21.5	22.6	-	-
1½"	-	23.2	29.7	-
2"	-	-	29.8	35.7
3"	-	-	-	36.4
ASME 600				
½"	21.3	-	-	-
¾"	21.6	-	-	-
1"	22	23.2	-	-
1½"	-	23.7	30.3	-
2"	-	-	30.5	36.4
3"	-	-	-	37.2
JIS 10K				
50A	-	-	28	33.9
80A	-	-	-	34.7
JIS 20K				
15A	19.6	-	-	-
25A	19.8	20.9	-	-
40A	-	21.3	27.8	-
50A	-	-	28	33.9
80A	-	-	-	34.7

2.6.2 Hygienic versions

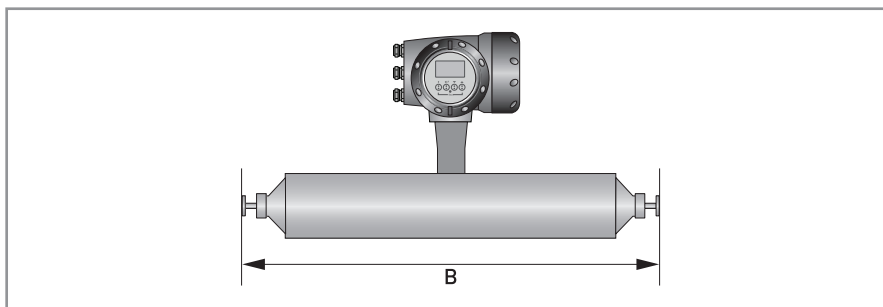

Hygienic connections: all welded versions

	Dimension B [mm]			
	S15	S25	S40	S50
Tri-clover				
1"	487	-	-	-
1½"	-	534	-	-
2"	-	-	691	-
3"	-	-	-	832
Tri-clamp DIN 32676				
DN10	-	-	-	-
DN15	-	-	-	-
DN25	468	-	-	-
DN40	-	515	-	-
DN50	-	-	677	-
DN80	-	-	-	836
Tri-clamp ISO 2852				
1"	473	-	-	-
1½"	-	502	-	-
2"	-	-	667	-
3"	-	-	-	817
DIN 11864-2 form A				
DN25	505	-	-	-
DN40	-	562	-	-
DN50	-	-	724	-
DN80	-	-	-	896

	Dimension B [inches]			
	S15	S25	S40	S50
Tri-clover				
1"	19.2	-	-	-
1½"	-	21	-	-
2"	-	-	27.2	-
3"	-	-	-	32.7
Tri-clamp DIN 32676				
DN10	-	-	-	-
DN15	-	-	-	-
DN25	18.4	-	-	-
DN40	-	20.3	-	-
DN50	-	-	26.6	-
DN80	-	-	-	32.9
Tri-clamp ISO 2852				
1"	18.6	-	-	-
1½"	-	19.8	-	-
2"	-	-	26.3	-
3"	-	-	-	32.2
DIN 11864-2 form A				
DN25	19.9	-	-	-
DN40	-	22.2	-	-
DN50	-	-	28.5	-
DN80	-	-	-	35.3

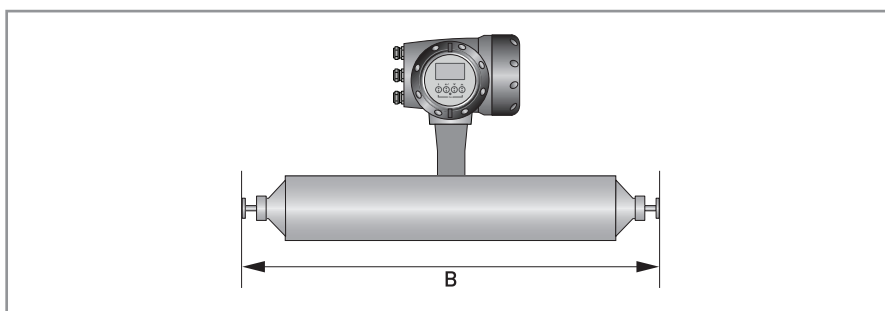

Hygienic connections: adapter versions (male thread)

	Dimension B [mm]			
	S15	S25	S40	S50
Male thread DIN 11851				
DN25	483	-	-	-
DN40	-	538	-	-
DN50	-	-	704	-
DN80	-	-	-	870
Male thread SMS				
1"	474	-	-	-
1½"	-	537	-	-
2"	-	-	694	-
3"	-	-	-	837
Male thread IDF/ISS				
1"	487	-	-	-
1½"	-	534	-	-
2"	-	-	691	-
3"	-	-	-	832
Male thread RJT				
1"	498	-	-	-
1½"	-	545	-	-
2"	-	-	702	-
3"	-	-	-	843

	Dimension B [inches]			
	S15	S25	S40	S50
Male thread DIN 11851				
DN25	19	-	-	-
DN40	-	21.2	-	-
DN50	-	-	27.7	-
DN80	-	-	-	34.2
Male thread SMS				
1"	18.7	-	-	-
1½"	-	21.1	-	-
2"	-	-	27.3	-
3"	-	-	-	32.9
Male thread IDF/ISS				
1"	19.2	-	-	-
1½"	-	21	-	-
2"	-	-	27.2	-
3"	-	-	-	32.7
Male thread RJT				
1"	19.6	-	-	-
1½"	-	21.4	-	-
2"	-	-	27.6	-
3"	-	-	-	33.2

2.6.3 Heating jacket version

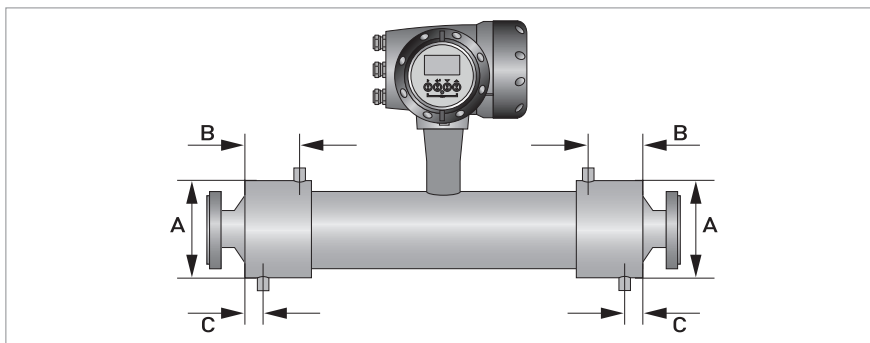

	Dimensions [mm]			
	S15	S25	S40	S50
Heating connection size	12 mm (ERMETO)			25
A	115 ±1	142 ±1	206 ±1	254 ±1
B	51	55	90	105
C	20			26

	Dimensions [inches]			
	S15	S25	S40	S50
Heating connection size	½" (NPTF)			1
A	4.5 ±0.04	5.6 ±0.04	8.1 ±0.04	10 ±0.04
B	2.0	2.2	3.5	4.1
C	0.8			1.0

2.6.4 Purge port option

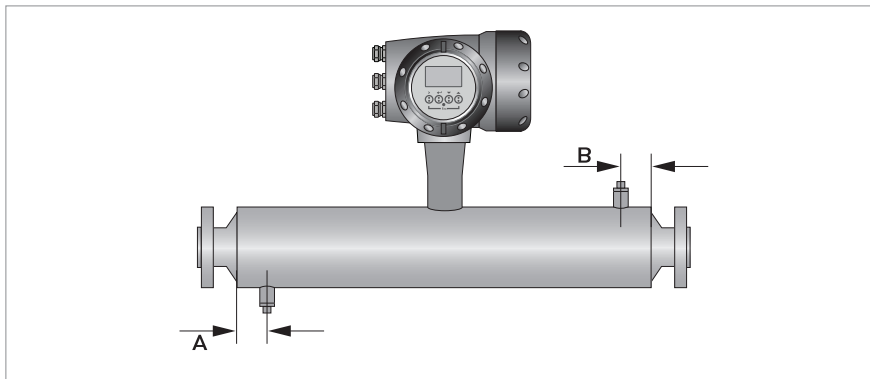

	Dimensions [mm]			
	S15	S25	S40	S50
A	55 ±1.0		65 ±1.0	
B	55 ±1.0		65 ±1.0	

	Dimensions [inches]			
	S15	S25	S40	S50
A	2.2 ±0.04		2.5 ±0.04	
B	2.2 ±0.04		2.5 ±0.04	

3.1 Intended use

This mass flowmeter is designed for the direct measurement of mass flow rate, product density and product temperature. Indirectly, it also enables the measurement of parameters like total mass, concentration of dissolved substances and the volume flow. For use in hazardous areas, special codes and regulations are also applicable and these are specified in a separate documentation.

3.2 Mounting restrictions

3.2.1 General installation principles

There are no special installation requirements but you should note the following points:

- Support the weight of the meter.
- The meter can be supported on the sensor body.
- On larger meter sizes and hygienic connections, it is strongly recommended that the meter is not supported solely by the process pipework.
- No straight runs are required.
- The use of reducers and other fittings at flanges, including flexible hoses, is allowed but you should take care to avoid cavitation.
- Avoid extreme pipe size reductions.
- Meters are not affected by crosstalk and can be mounted in series or in parallel.
- Avoid mounting the meter at the highest point in the pipeline where air / gas can collect.

Mounting positions

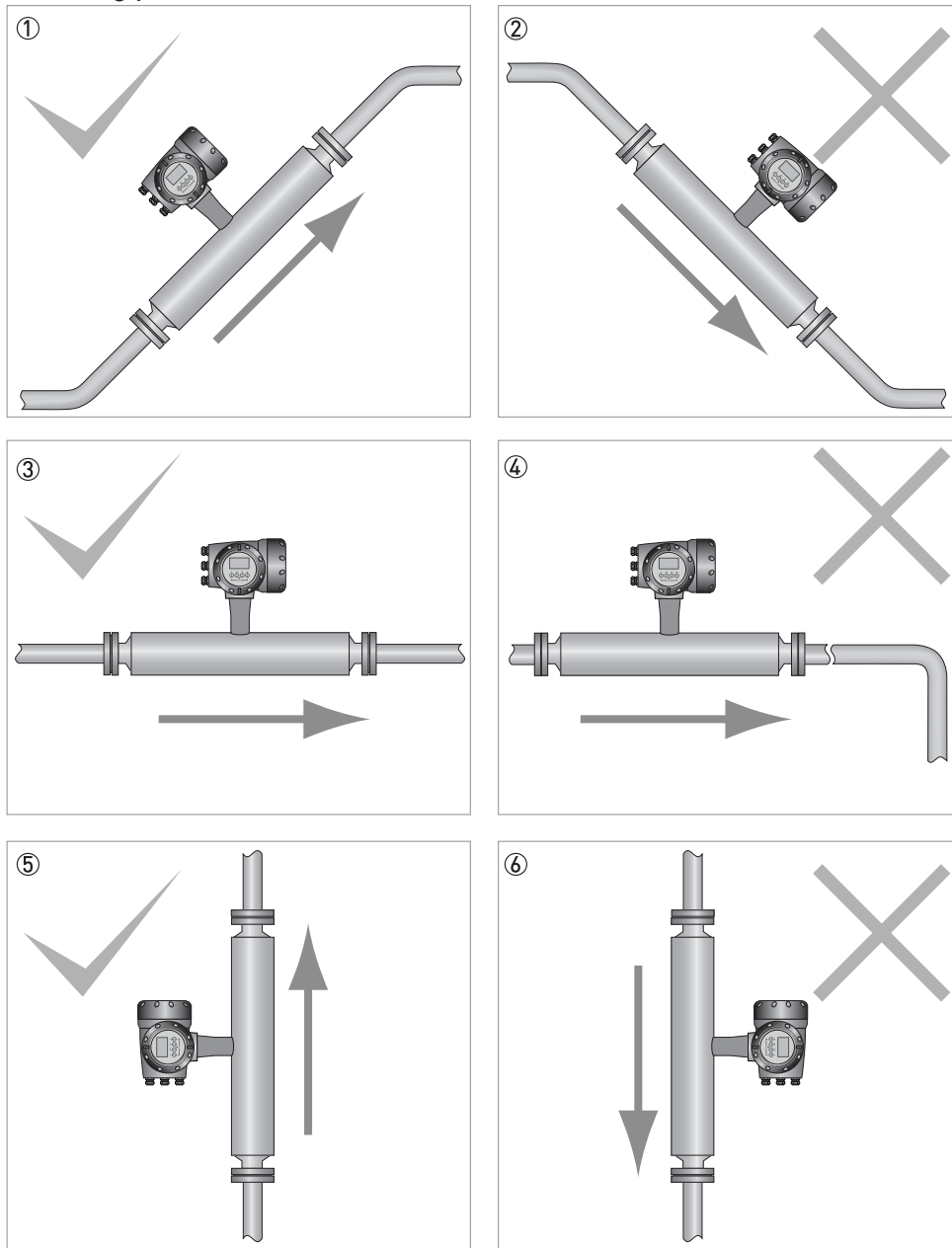

- ① The meter can be mounted at an angle but it is recommended that the flow is uphill.
- ② Avoid mounting the meter with the flow running downhill because it can cause siphoning. If the meter has to be mounted with the flow running downhill, install an orifice plate or control valve downstream of the meter to maintain backpressure.
- ③ Horizontal mounting with flow running left to right.
- ④ Avoid mounting meter with long vertical runs after the meter as it can cause cavitation. Where the installation includes a vertical run after the meter, install an orifice plate or control valve downstream to maintain backpressure.
- ⑤ The meter can be mounted vertically but it is recommended that the flow is uphill.
- ⑥ Avoid mounting the meter vertically with the flow running downhill. This can cause siphoning. If the meter has to be installed this way, install an orifice plate or control valve downstream to maintain backpressure.

Zero calibration

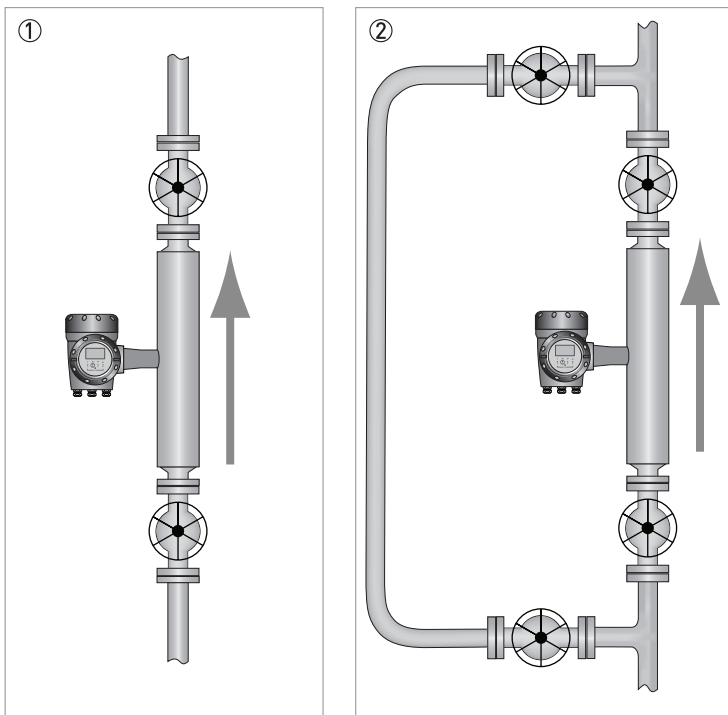

- ① Where the meter has been installed vertically, install shut-off valves either side of the meter to assist with zero calibration.
- ② If the process flow cannot be stopped, install a bypass section for zero calibration.

3.2.2 Sunshades

The meter MUST be protected from strong sunlight.

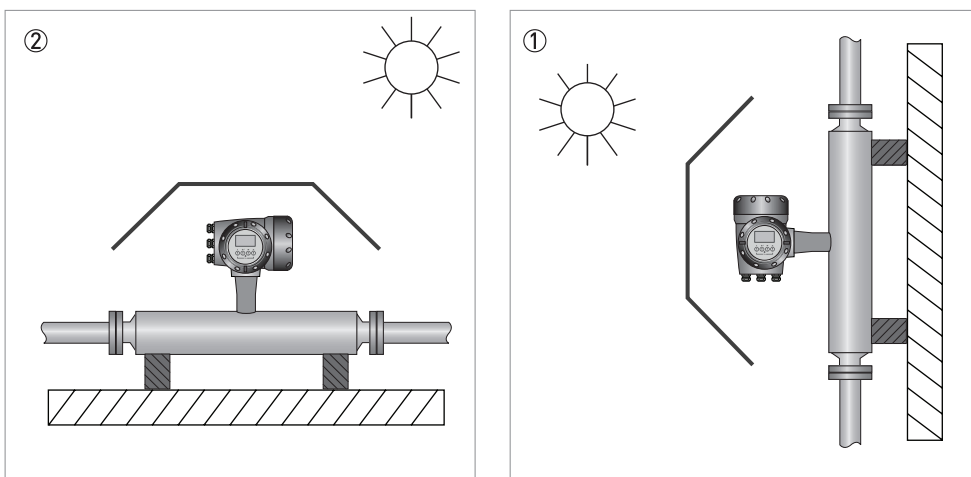

- ① Horizontal installation
- ② Vertical installation







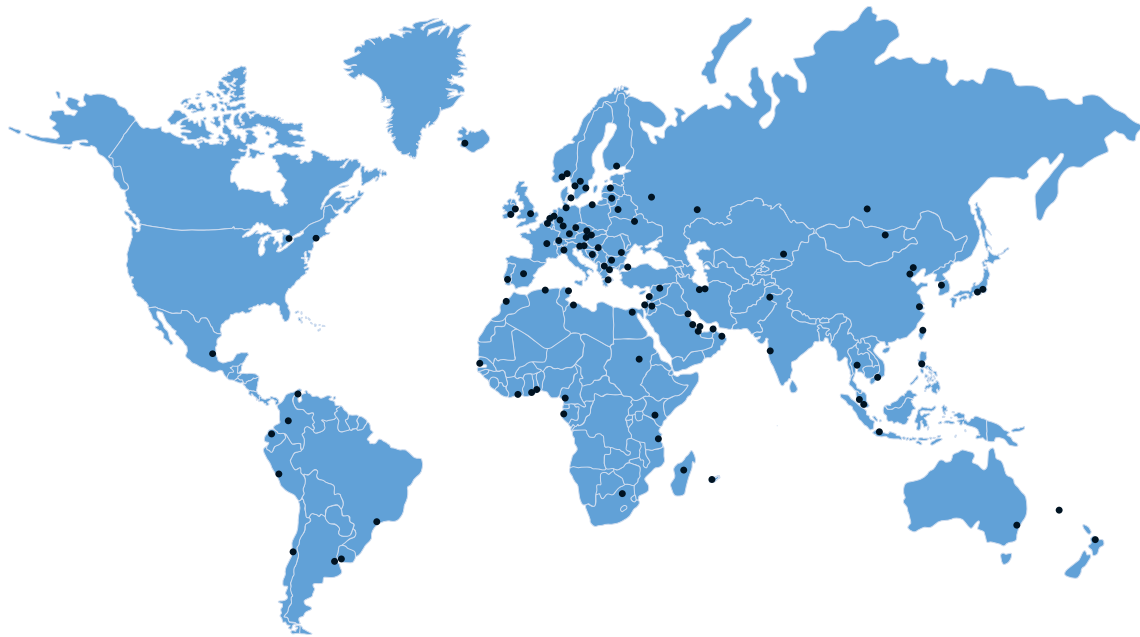

KROHNE product overview

- Electromagnetic flowmeters
- Variable area flowmeters
- Ultrasonic flowmeters
- Mass flowmeters
- Vortex flowmeters
- Flow controllers
- Level meters
- Temperature assemblies
- Pressure transmitters
- Analysis products
- Products and systems for the oil & gas industry
- Measuring systems for the marine industry

Head Office KROHNE Messtechnik GmbH
Ludwig-Krohne-Str. 5
47058 Duisburg (Germany)
Tel.: +49 203 301 0
Fax: +49 203 301 103 89
info@krohne.com

The current list of all KROHNE contacts and addresses can be found at:
www.krohne.com

KROHNE