

MK 45-1  
DN 15, 20, 25  
RHOMBUSline®

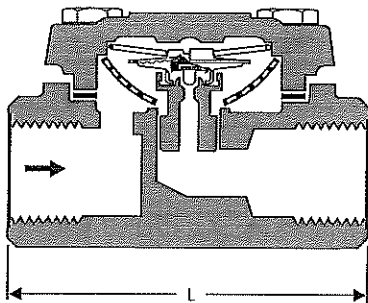

MK 35/31, DN 10, 15

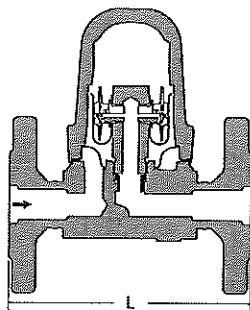

MK 35/2 S, DN 25

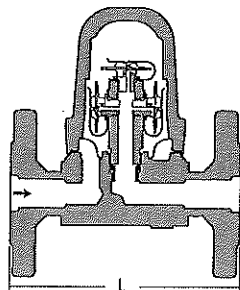

MK 35/2 S3, DN 25

### Features of the MK series

- Very sensitive response characteristic
- Function is not impaired by high back pressure
- Automatic air-venting (trap can be used for thermal air-venting in steam systems)
- Installation in any position (horizontal and vertical lines)
- High hot-water capacities even with low differential pressures
- With tandem seat (double sealing) for low condensate flowrates
- Built-in non-return valve (only MK 45)
- Stainless steel internals (corrugated membrane of Hastelloy)
- Design "U" with undercooling capsule: utilization of a certain amount of sensible heat by banking-up of condensate, decreasing the amount of flash steam
- Optional extra: Integrated condensate monitoring for MK 45 (temperature or steam loss)

### Application

Type		
MK 45-1 MK 35/31 <sup>1)</sup>		With tandem seat (double sealing) For low condensate flowrates, steam-tracing, steam-line drainage, air-venting
MK 45-2 MK 35/32 <sup>1)</sup>		With single seat For medium condensate flowrates, steam-tracing, drainage of heat exchangers, air-venting
MK 25/2 <sup>1)</sup> MK 25/2 S <sup>1)</sup> MK 35/2 S <sup>1)</sup> MK 35/2 S3 <sup>1)</sup>		With single seat For large condensate flowrates, drainage of heat exchangers
MK 36/51 <sup>1)</sup> MK 36/52 <sup>1)</sup>		With tandem seat (double sealing) – with flat gasket For small/large condensate flowrates, steam tracing, steam-line drainage, venting and vacuum-breaking. Also suitable for food, biological and pharmaceutical applications.
MK 45 A-1 MK 45 A-2		For small and large condensate flowrates; steam-tracing, steam-line drainage, air-venting

<sup>1)</sup> Can also be used for vacuum breaking (aerating).

### Air Venting

#### Steam Trap for Thermostatic Air-Venting with Membrane Regulator

The thermostatic steam traps with membrane regulators of the MK series can also be used for air-venting.

#### Application

Thermostatic steam trap for automatic air-venting and discharge of non-condensable gases and steam/air mixtures from steam lines and heat exchangers.

A special type of membrane regulator capsule might be required.

### Pressure/Temperature Ratings

Type	PN / Class	$\Delta$ PMX [bar]	Material		Max. Pressure/Temp. Rating <sup>1)</sup>			
			EN	ASTM	PMA [bar]	TMA [°C]	p/T [bar/°C]	
MK 35/31, MK 35/32	PN 25	21	1.0460	A105	25.0	400	18.6 / 225	14.4 / 400
MK 45-1, MK 45-2	PN 40	32	1.0460	A105	40.0	450	27.6 / 300	13.1 / 450
MK 45-1, MK 45-2	Class 300	32	1.0460	A105	51.1	425	39.8 / 300	28.8 / 425
MK 35/2 S, DN 25 MK 35/2 S3, DN 25	PN 40	32	1.0460	A105	40.0	450	27.6 / 300	13.1 / 450
MK 25/2, MK 25/2 S, DN 40, 50	PN 40	32	1.0460/ 1.0619	A105/ A216-WCB	40.0	450	27.6 / 300	13.1 / 450
MK 36/51, MK 36/52	–	32	1.4301 <sup>2)</sup>	A479-F304	49.0	400	32.0 / 250	28.0 / 400
MK 45 A-1, MK 45 A-2	PN 40	32	1.4404	A182-F316L	40.0	400	27.6 / 300	25.7 / 400 <sup>3)</sup>
MK 45 A-1, MK 45 A-2	Class 300	32	1.4404	A182-F316L	41.4	400	26.1 / 300	24.3 / 400 <sup>3)</sup>

<sup>1)</sup> Limits for body/cover. Functional requirements may restrict the use to below the limits quoted.

For full details on limiting conditions depending on end connection and type of regulator see data sheet.

<sup>2)</sup> EN material comparable to ASTM material.

<sup>3)</sup> If the operating temperatures exceed 300 °C intercrystalline corrosion may occur. Do not subject the equipment to operating temperatures higher than 300 °C unless intercrystalline corrosion can be ruled out.

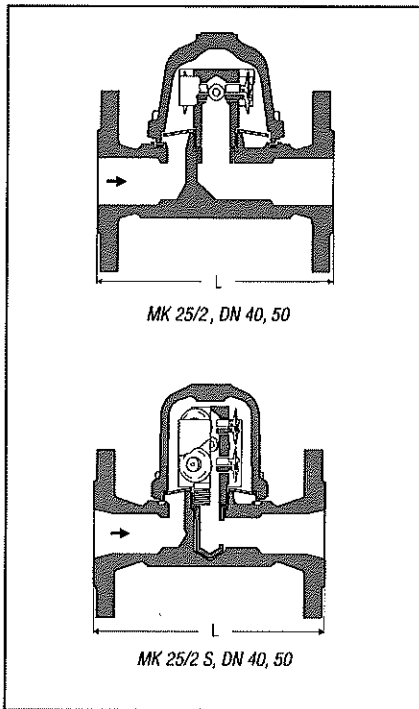

Available End Connections and Overall Length

Type	Connection	Overall length (L) in mm						
		DN 8 1/4"	DN 10 3/8"	DN 15 1/2"	DN 20 3/4"	DN 25 1"	DN 40 1 1/2"	DN 50 2"
MK 45-1	Flanged EN PN 40	–	–	150	150	160	–	–
MK 45-2	Flanged ASME 150 <sup>1)</sup>	–	–	150	150	160	–	–
MK 45 A-1	Flanged ASME 300 <sup>1)</sup>	–	–	150	150	160	–	–
MK 45 A-2	Screwed sockets	–	–	95	95	95	–	–
MK 35/2 S3 only DN 25	Socket-weld (SW)	–	–	95	95	95	–	–
MK 35/2 S only DN 25	Butt-weld (BW) <sup>2)</sup>	–	–	200	200	200	–	–
MK 35/31	Screwed sockets	–	70	70	–	–	–	–
MK 35/32	Socket-weld (SW)	–	–	95	–	–	–	–
MK 25/2 DN 40 – 50	Flanged EN PN 40	–	–	–	–	–	230	230
MK 25/2 S DN 40 – 50	Flanged ASME 150	–	–	–	–	–	230	230
	Flanged ASME 300	–	–	–	–	–	230	230
	Screwed sockets	–	–	–	–	–	130	230
	Socket-weld (SW)	–	–	–	–	–	130	230
MK 36/51	Screwed sockets	65	65	65	65	–	–	–
MK 36/52	Union butt-weld nipples <sup>3)</sup>	–	–	150	–	–	–	–
	Hinged clamp	–	65	65	65	65	–	–

1) MK 45 with ASME flanges: overall length 172 mm available on request.

2) Only MK 45

3) Made of carbon steel or stainless steel

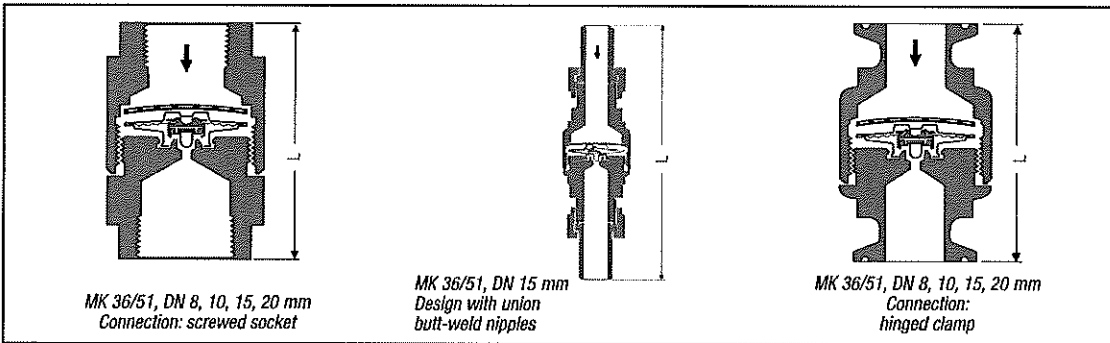

Capacity Charts

The charts show the maximum hot condensate capacities.

MK 45-1/MK 45A-1 (Curve 4) MK 35/31 (Curve 1)  
 MK 45-2/MK 45A-2 (Curve 5) MK 35/32 (Curve 2)  
 MK 36/51 (Curve 3) MK 36/52 (Curve 2)

MK 25/2 S, DN 40, 50 (Curve 1) MK 35/2 S3, DN 25 (Curve 3)  
 MK 25/2, DN 40, 50 (Curve 2) MK 35/2S, DN 25 (Curve 4)

