



200 Series Cast Iron Inverted Bucket Steam Traps

Description

The Spirax Sarco 200 Series of inverted bucket steam traps are designed for installation in vertical pipework. With cast iron bodies and bolted cover they are maintainable and offer a very wide range of capacities, in applications up to 17 bar g.

Certification

This product is available with certification to EN 10204 2.2.

Note: All certification/inspection requirements must be stated at the time of order placement.

Sizes and pipe connections

½" - 2" screwed BSP or NPT

DN15 - 50 flanged*

*Flanges meet the requirements of BS 4504 DIN PN16, PN10, PN6 and ANSI 125 and ANSI 150.

In some sizes the inlet and outlet flanges are formed from the body casting and have tapped holes to receive studs.

The stud holes are tapped UNC in ANSI flanges and metric in BS 4504 DIN flanges.

Limiting conditions

Note: Maximum operating conditions depend on the orifice size.

Body design conditions	PN16
PMO Maximum operating pressure	22 bar g @ 210 °C
TMO Maximum operating temperature	210 °C @ 22 bar g
Designed for a maximum cold hydraulic test pressure of	34 bar g

Δ PMX - Maximum differential pressure

Screwed valves

Size	Δ PMX - Maximum differential pressure bar						
	2	2.5	4	8.5	12.5	13.8	17
½"	211/12	-	211/10	211/8	-	211/7	211/6
¾"	212/16	-	212/12	212/10	-	212/8	212/7
1"	213/24	-	213/20	213/16	213/14	-	213/12
1½"	215/36	-	215/28	215/22	215/20	-	215/18
2"	-	216/48	216/40	216/32	216/28	-	216/24

Flanged valves

Size	Δ PMX - Maximum differential pressure bar						
	2	2.5	4	8.5	12.5	13.8	17
DN15	221/12	-	221/10	221/8	-	221/7	221/6
DN20	222/16	-	222/12	222/10	-	222/8	222/7
DN25	223/24	-	223/20	223/16	223/14	-	223/12
DN40	225/36	-	225/28	225/22	225/20	-	225/18
DN50	-	226/48	226/40	226/32	226/28	-	226/24

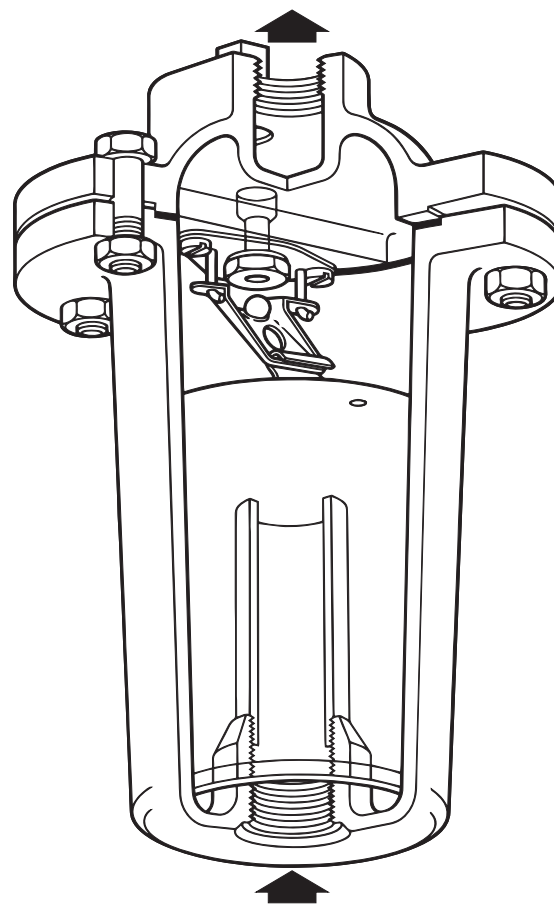

Screwed version shown
 (for details of the flanged version see overleaf)

Materials

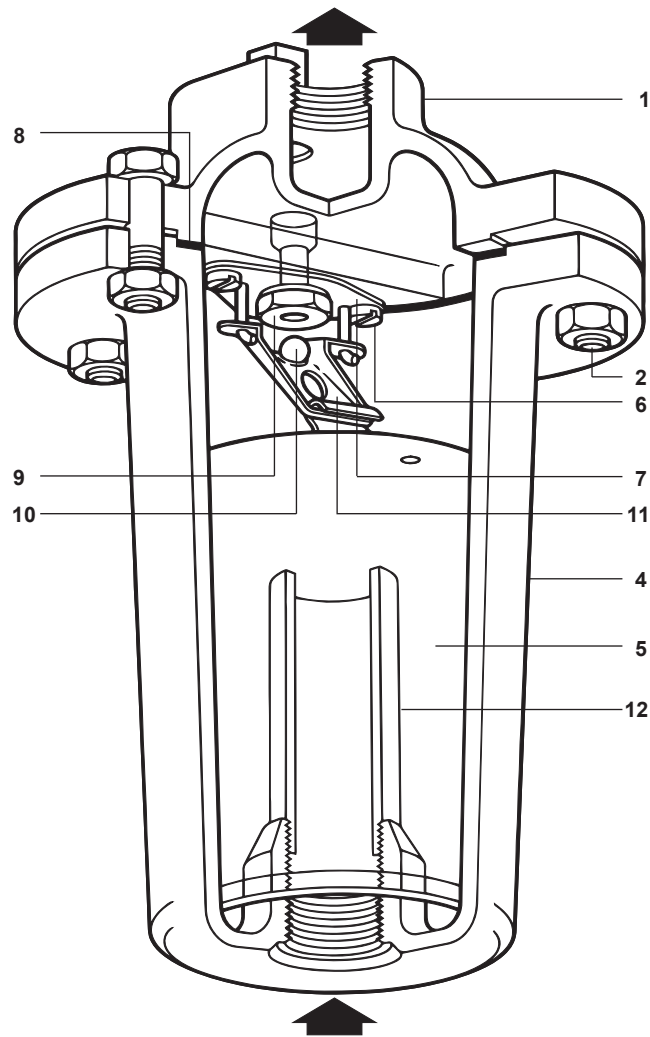

No.	Part	Material	
1	Cover	Cast iron	DIN 1691 GG 20
2	Cover bolts	Steel	BS 3692 Gr. 8.8
	Cover nuts	Steel	BS 3692 Gr. 8
4	Body	Cast iron	DIN 1691 GG 20
5	Bucket	Stainless steel	BS 1449 321 S31
6	Valve guide plate screws	Stainless steel	BS 4183 (18/8)
7	Valve guide plate	Stainless steel	BS 1449 321 S31
8	Cover gasket	Reinforced exfoliated graphite	
9	Valve seat	Stainless steel	AISI 440B
10	Valve	Stainless steel	AISI 440B
11	Valve lever	Stainless steel	BS 1449 321 S31
12	Internal tube	Steel	BS 1387 (MED)

Capacities

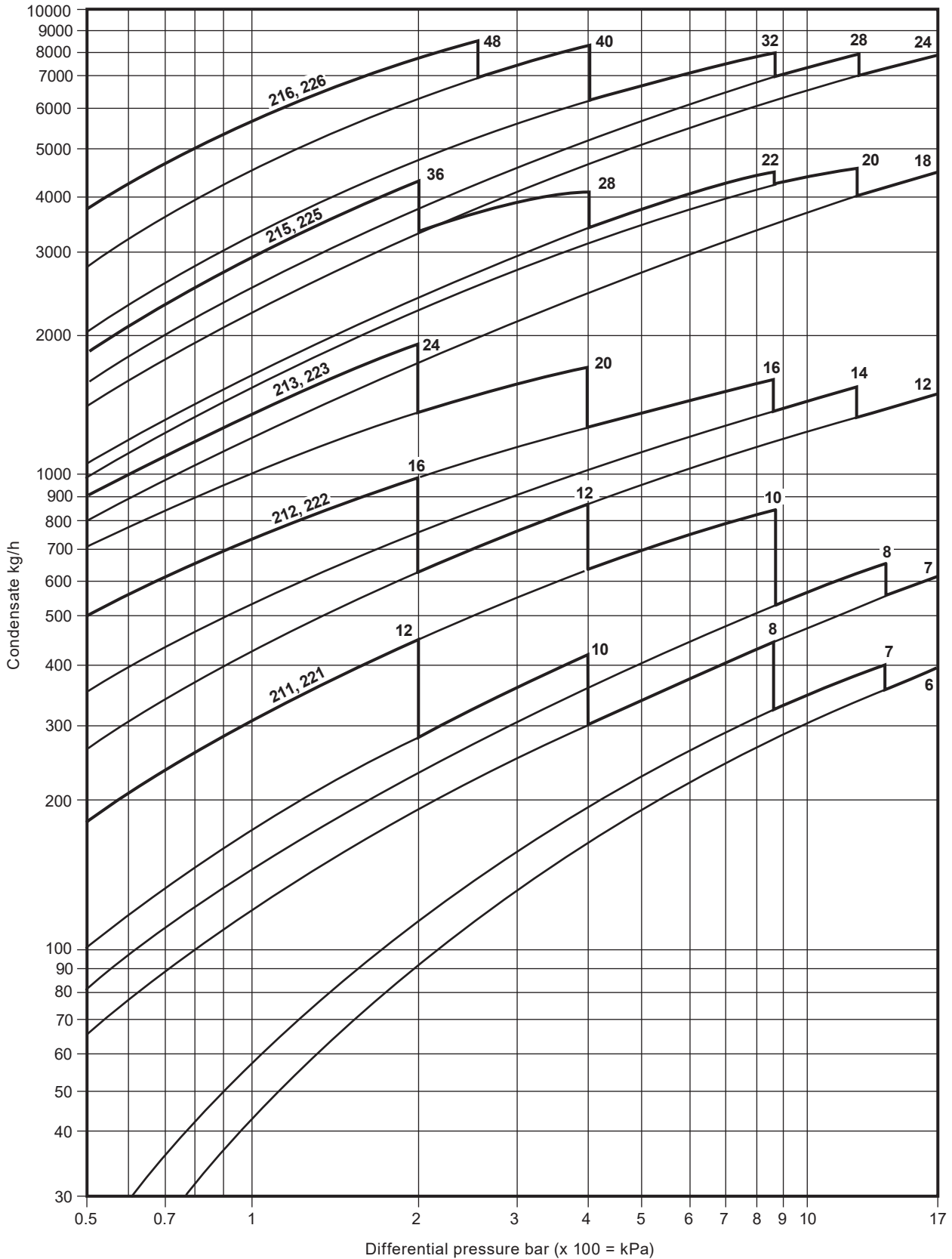

Note: Traps should be selected for the most appropriate working pressure differential and not on the basis of load.

Dimensions/weight (approximate) in mm and kg

Type	Size	A	B	C	D	Weight	
Screwed	Type 211	1/2"	163	108	178	67	2.8
	Type 212	3/4"	200	135	229	93	5.2
	Type 213	1"	269	188	280	114	12.2
	Type 215	1 1/2"	365	238	380	140	27.0
	Type 216	2"	432	286	470	185	43.5
Flanged	Type 221	DN15	215	108	254	-	4.9
	Type 222	DN20	286	135	280	-	9.1
	Type 223	DN25	305	188	305	121	16.3
	Type 225	DN40	370	238	380	140	30.8
	Type 226	DN50	450	286	457	165	49.4

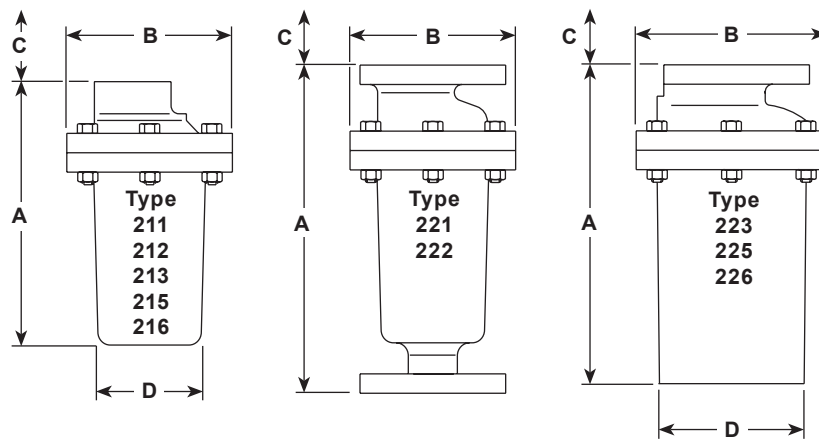

Safety information, installation and maintenance

For full details see the Installation and Maintenance Instructions (IM-S03-08) supplied with the product.

The trap must be installed with the body upright so that the bucket is rising and falling vertically. The inlet should be at the bottom with the trap installed below the drain point so that a water seal can be maintained around the end of the bucket.

Disposal

The product is recyclable. No ecological hazard is anticipated with disposal of this product providing due care is taken.

How to order

Example: 1 off DN40 225/18 Spirax Sarco inverted bucket steam trap with flanged PN16 connections.

Spare parts

The spare parts available are shown in heavy outline. Parts drawn in a grey line are not supplied as spares.

Available spares

Valve and seat assembly (state pressure range)	6 (2 off), 7, 9, 11
Bucket	5
Internal tube	12
Cover gasket (packet of 3)	8



How to order spares

Always order spares by using the description given in the column headed 'Available spares' and state the size and full definition of the trap e.g. 212/10.

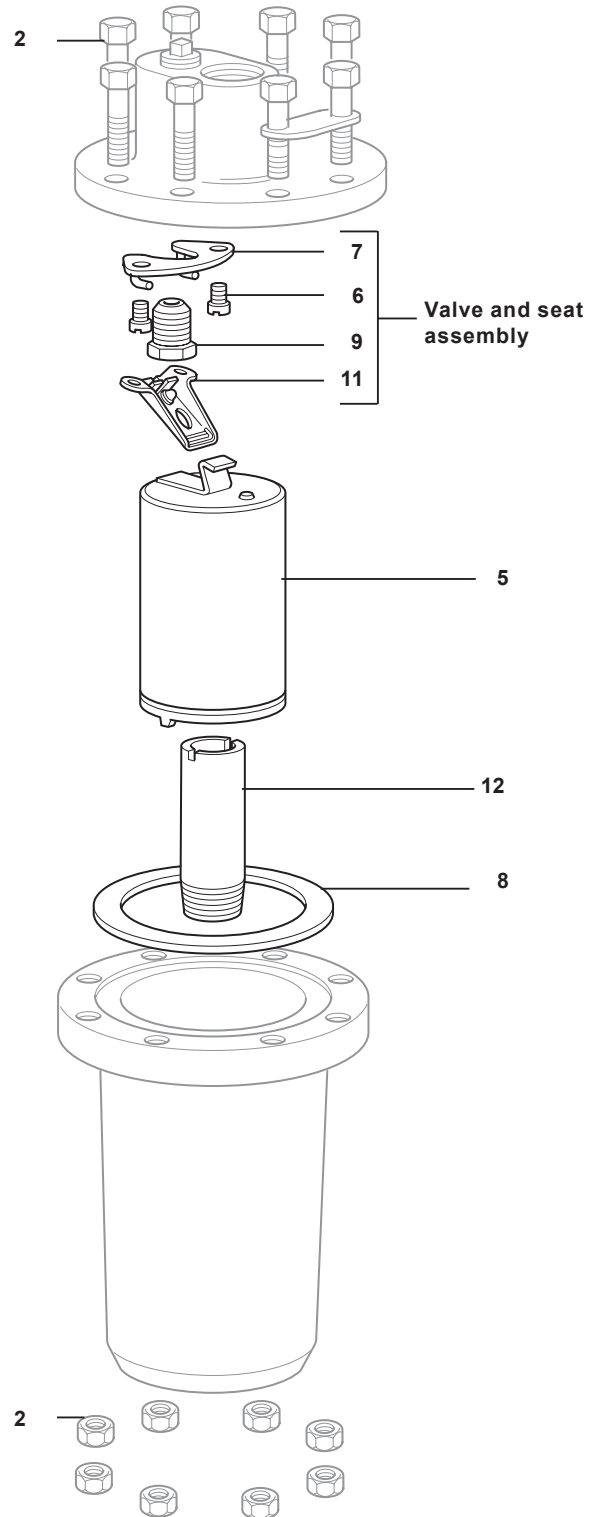
Example: 1 - Valve and seat assembly for a ¾" Spirax Sarco inverted bucket steam trap Series 212/10.



Recommended tightening torques

Item	Part	 or 	mm	N m
2 (6 off)	½" - DN15		M8 x 35	18 - 22
2 (8 off)	¾" - DN20		M10 x 40	16 - 20
2 (10 off)	1" - DN25		M12 x 60	24 - 28
2 (12 off)	1½" - DN40		M16 x 75	60 - 66
2 (12 off)	2" - DN50		M16 x 75	64 - 70
6	½" - DN15		2BA x 5/16"	4 - 5
	¾" - DN20		2BA x 5/16"	4 - 5
	1" - DN25		¼" WHIT x ½"	10 - 12
	1½" - DN40		¼" WHIT x ½"	10 - 12
9	2" - DN50		⅝" WHIT x ½"	14 - 16
	½" - DN15	½"AF		23 - 27
	¾" - DN20	⅝"AF		40 - 44
9	1" - DN25	⅞"AF		80 - 88
	1½" - DN40	1¼"AF		175 - 190
	2" - DN50	1½"AF		270 - 300
12	½" - 2"	1½"AF		60 - 70
	DN15 - DN50			