

DESIGN FEATURES:

- Steam rating: 150 psi WSP
- WORKING PRESSURE : 2000 PSI
- INVESTMENT CASTING BODY & CAP
- ME-PTFE SEAL KITS : REPLACES PTFE ,RPTFE AND FPA
 LOW DEFORMATION UNDER LOAD
 LOW PERMEATION
- TEMPERATURE RATING : -45.5°C (-50°F) to 246°C (475°F)
- LONG CYCLE LIFE
- ADJUSTABLE STEM PACKING
- BLOW-OUT PROOF STEM
- LOCKING DEVICE
- DESIGN SPECIFICATION : ANSI B16.34 CLASS 900
- TEST STANDARD:API 598
- Vacuum Service to 29" Hg
- NACE MR-0175 FULL COMPLIANCE

BALL VALVE SERIES 101 2PC FULL PORT WOG

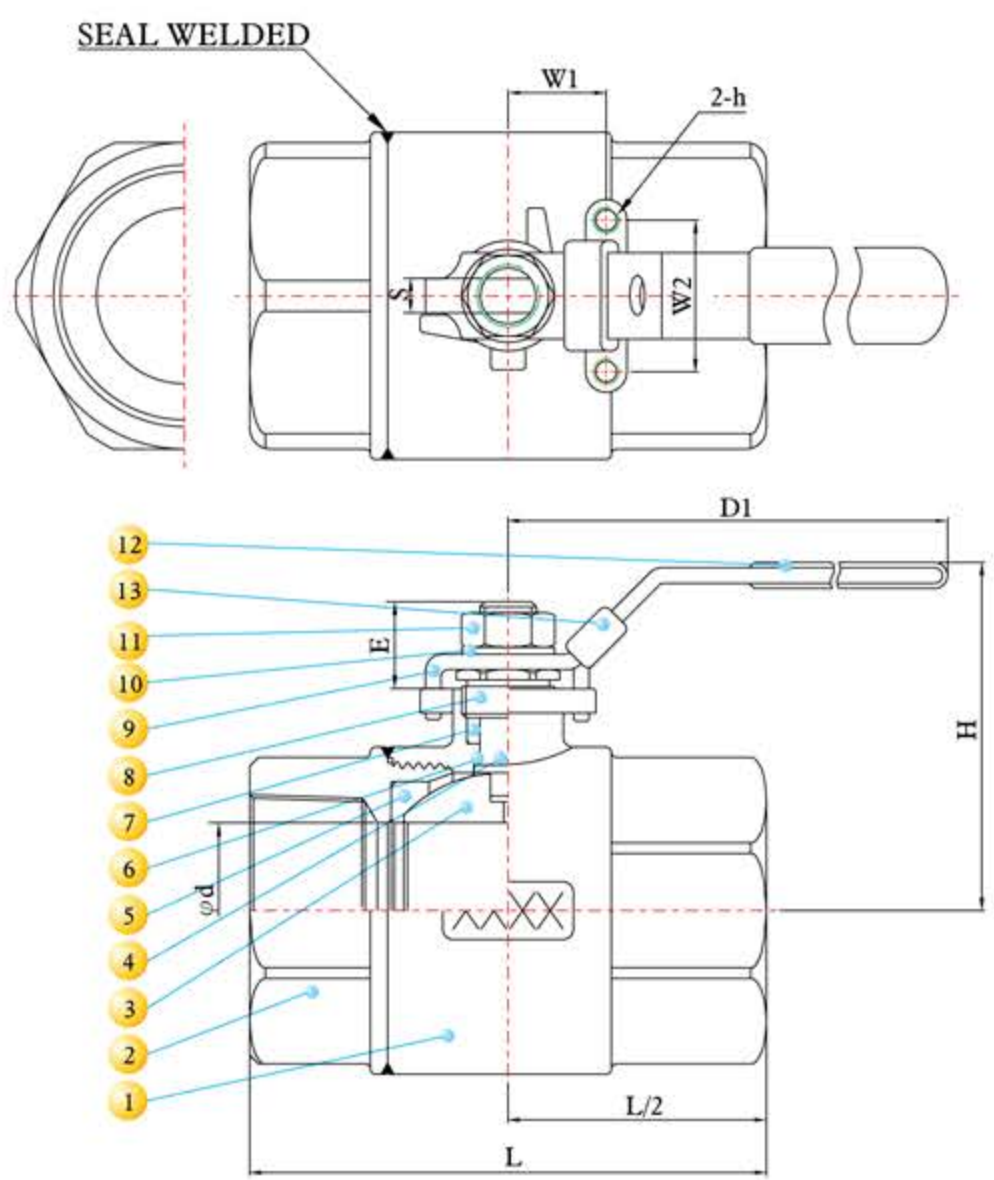

MATERIALS LIST

NO.	PART NAME	MATERIAL	Q'TY
1	BODY	ASTM A351 Gr.CF8M	1
2	CAP	ASTM A351 Gr.CF8M	1
3	BALL	ASTM A351 Gr.CF8M	1
4	STEM	ASTM A276 Gr.316	1
5	SEAT	PTFE	2
6	THRUST WASHER	PTFE	1
7	PACKING	PTFE	1
8	GLAND	PTFE	1
9	HANDLE	SS304	1
10	SPRING WASHER	SS304	1
11	HANDLE NUT	SS304	1
12	HANDLE SLEEVE	VINYL GRIP	1
13	LOCKING PLATE	SS304	1

PRESSURE TEMPERATURE RATINGS

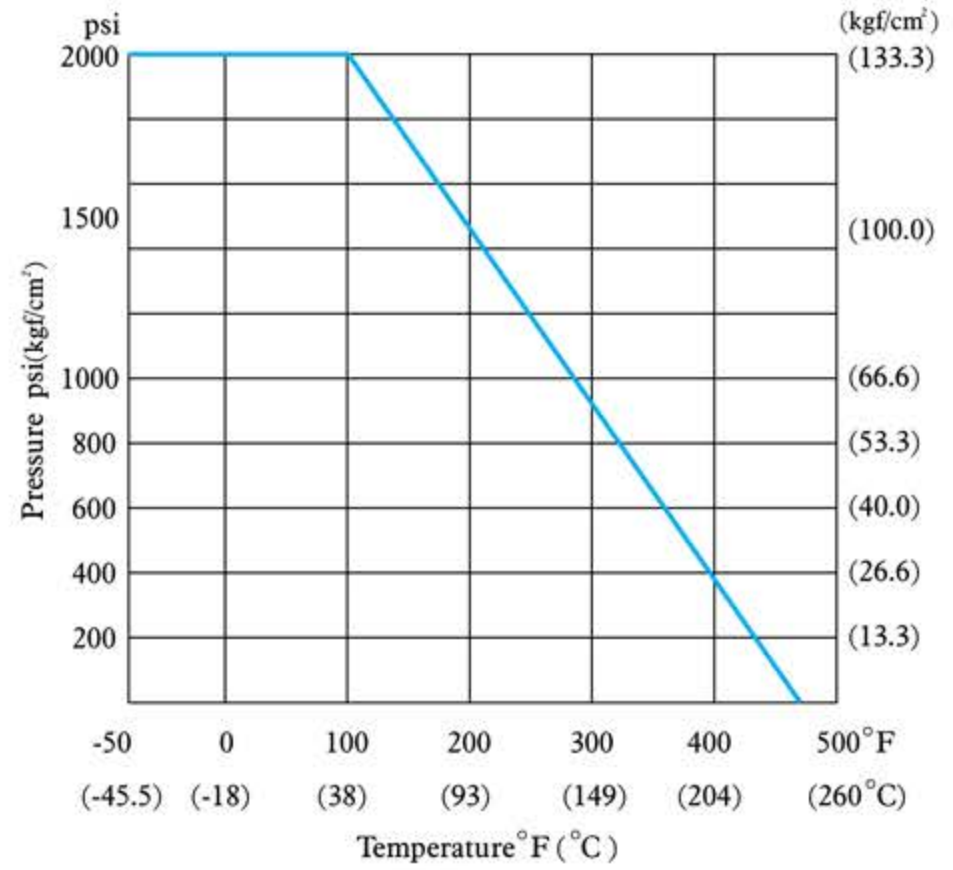

DIMENSIONS

SIZE	d	L	E	S	H	D1	W1	W2	h	CV	Weight
inch mm	inch mm	inch mm	inch mm	inch mm	inch mm	inch mm	inch mm	inch mm	(Option)	Factor	Kg Lb
1/4" 8	0.43 11.0	2.34 59.5	0.61 15.5	0.21 5.45	2.24 57.0	4.06 103	0.50 12.7	1.12 28.5	M5*P0.8	16	0.37 0.81
3/8" 10	0.49 12.5	2.34 59.5	0.61 15.5	0.21 5.45	2.24 57.0	4.06 103	0.50 12.7	1.12 28.5	M5*P0.8	16	0.36 0.79
1/2" 15	0.59 15.0	2.54 64.5	0.57 14.5	0.21 5.45	2.27 57.6	4.06 103	0.50 12.7	1.12 28.5	M5*P0.8	26	0.42 0.93
3/4" 20	0.79 20.0	3.03 77.0	0.80 20.3	0.24 6.20	2.70 68.5	5.00 127	0.88 22.4	1.38 35.0	M6*P1.0	55	0.80 1.76
1" 25	0.98 25.0	3.56 90.5	0.75 19.0	0.24 6.20	2.86 72.7	5.00 127	0.88 22.4	1.38 35.0	M6*P1.0	110	1.24 2.73
1-1/4" 32	1.26 32.0	3.92 99.5	1.10 27.9	0.37 9.40	3.45 87.7	6.14 156	1.00 25.4	1.50 38.1	M6*P1.0	180	2.05 4.52
1-1/2" 40	1.50 38.0	4.65 118.0	1.05 26.7	0.37 9.40	3.66 93.0	7.60 193	1.00 25.4	1.50 38.1	M6*P1.0	270	2.58 5.68
2" 50	2.00 50.8	5.37 136.5	1.05 26.7	0.37 9.40	4.11 104.3	7.60 193	1.00 25.4	1.50 38.1	M6*P1.0	500	4.43 9.76