

SERIES 102 BALL VALVES 1PC REDUCED PORT WOG BALL VALVE

DESIGN FEATURES:

- Steam rating: 125 psi WSP
- NACE MR-0175 full compliance
- Blow-out-proof stem design
- Padlocking device
- Body: ASTM A351 Gr.CF8M
- Stem: SS316
- Seat: PTFE
- End Connections: Threaded End
- Working Pressure: 2000 psi
- Temperature Range: -50° to 400° F
- TEST STANDARD: API 598
- Vacuum Service to 29" Hg
- API 607 5th Edition FIRE SAFE APPROVAL
- Threaded Type:
 ANSI B1.20.1 (NPT)
 DIN 259/DIN 2999
 ISO 228
 BSP
 PT



MATERIALS LIST

| NO. | PART NAME | MATERIAL | QTY |
|-----|----------------|-------------------|-----|
| 1 | BODY | ASTM A351 Gr.CF8M | 1 |
| 2 | BODY INSERT | ASTM A351 Gr.CF8M | 1 |
| 3 | CAP | ASTM A351 Gr.CF8M | 1 |
| 4 | BALL | ASTM A351 Gr.CF8M | 1 |
| 5 | STEM | ASTM A276 Gr.316 | 1 |
| 6 | SEAT | PTFE | 2 |
| 7 | GASKET | GRAFOIL | 1 |
| 8 | THRUST WASHER | PTFE | 1 |
| 9 | PACKING | GRAFOIL | 1 |
| 10 | WASHER | SS301 | 1 |
| 11 | CONCAVE WASHER | SS304 | 1 |
| 12 | STEM NUT | SS304 | 2 |
| 13 | HANDLE | SS304 | 1 |
| 14 | PLASTIC COVER | VINYL GRIP | 1 |
| 15 | LOCK NUT | SS304 | 1 |
| 16 | CAP INSERT | SS304 | 1 |

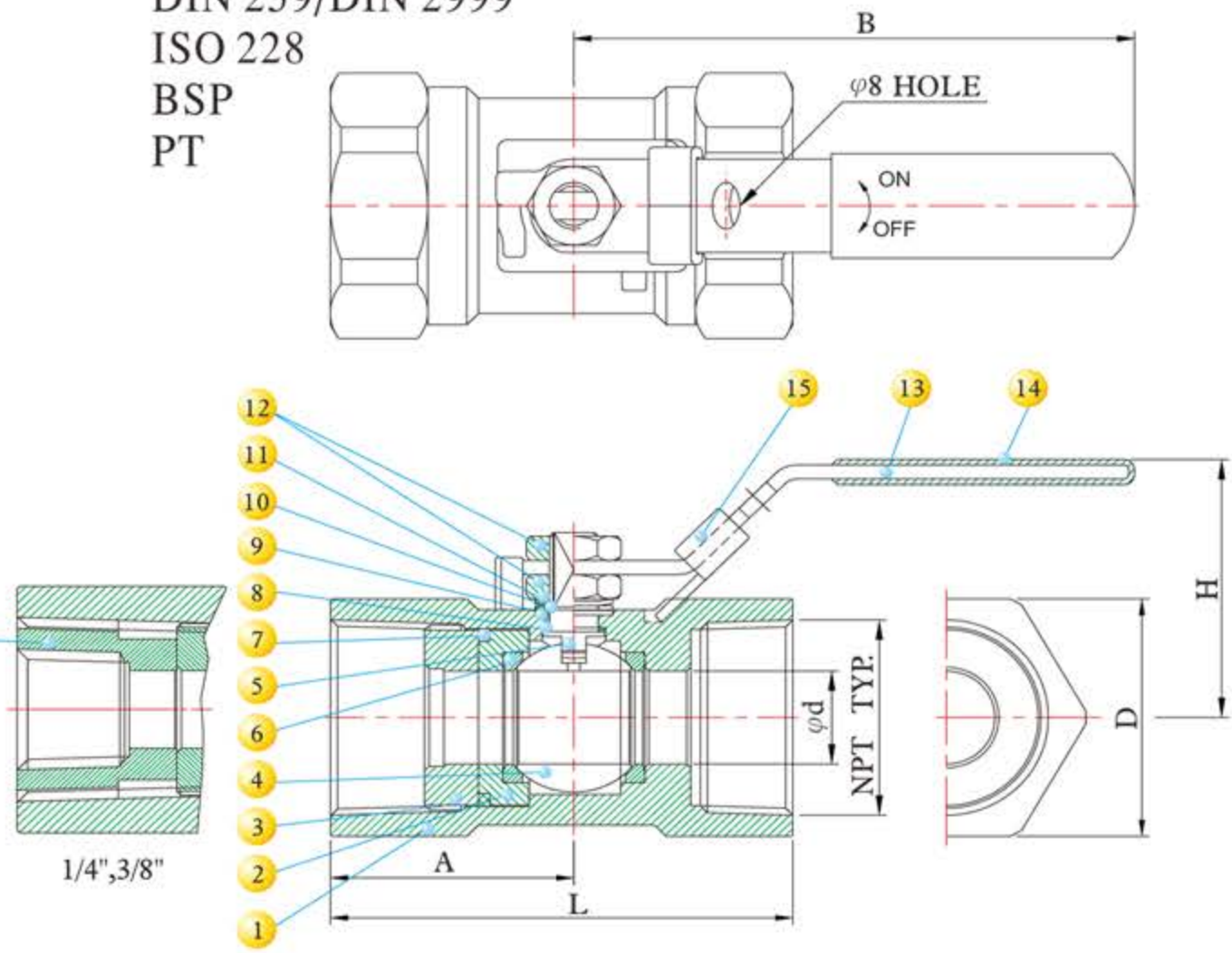

PRESSURE TEMPERATURE RATINGS

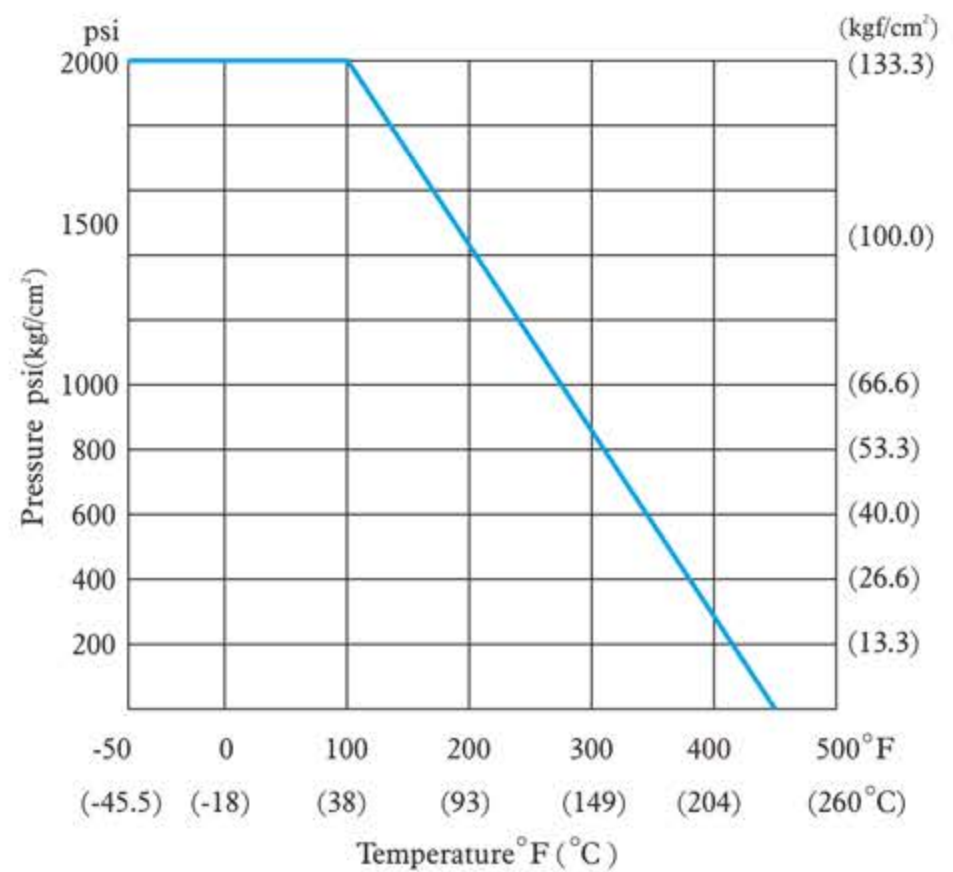

DIMENSIONS

| SIZE | | d | | A | | B | | D | | L | | H | | Cv Factor | Weight | |
|--------|----|------|------|------|------|------|-----|------|----|------|-------|------|------|-----------|--------|------|
| inch | mm | inch | mm | inch | mm | inch | mm | inch | mm | inch | mm | inch | mm | | Kg | Lb |
| 1/4" | 8 | 0.20 | 5.0 | 1.46 | 37.0 | 3.66 | 93 | 1.10 | 28 | 2.80 | 71.0 | 1.81 | 45.9 | 3.0 | 0.35 | 0.77 |
| 3/8" | 10 | 0.28 | 7.0 | 1.46 | 37.0 | 3.66 | 93 | 1.10 | 28 | 2.80 | 71.0 | 1.81 | 45.9 | 4.0 | 0.35 | 0.77 |
| 1/2" | 15 | 0.36 | 9.2 | 1.46 | 37.0 | 3.66 | 93 | 1.10 | 28 | 2.80 | 71.0 | 1.81 | 45.9 | 6.5 | 0.30 | 0.66 |
| 3/4" | 20 | 0.49 | 12.5 | 1.61 | 41.0 | 3.66 | 93 | 1.10 | 28 | 3.03 | 77.0 | 1.85 | 46.9 | 15.0 | 0.39 | 0.86 |
| 1" | 25 | 0.63 | 16.0 | 1.97 | 41.0 | 4.41 | 112 | 1.26 | 32 | 3.74 | 95.0 | 1.86 | 47.3 | 28.0 | 0.75 | 1.65 |
| 1 1/4" | 32 | 0.79 | 20.0 | 1.97 | 50.0 | 4.41 | 112 | 1.61 | 41 | 3.74 | 95.0 | 2.19 | 55.6 | 45.0 | 0.99 | 2.18 |
| 1 1/2" | 40 | 0.96 | 24.5 | 2.17 | 55.0 | 5.31 | 135 | 2.01 | 41 | 4.13 | 105.0 | 2.28 | 57.9 | 65.0 | 1.54 | 3.39 |
| 2" | 50 | 1.26 | 32.0 | 2.40 | 61.0 | 5.31 | 135 | 2.32 | 59 | 4.69 | 119.0 | 2.55 | 64.7 | 120.0 | 2.13 | 4.70 |